

Climate
Control

IMI TA

TA-Slider 500 BACnet/Modbus



Actuators

Digitally configurable proportional push-pull actuator for Bus communication with BACnet MS/TP or Modbus RTU – 500/300 N

TA-Slider 500 BACnet/Modbus

Digitally configurable actuators for Bus communication with BACnet MS/TP or Modbus RTU, and a wide range of setup options provide extensive flexibility for on-site parameter adaptation. Fully programmable binary input, relay and adjustable max. stroke of the valve bring new opportunities for advanced hydronic control and balancing.



Key features

Convenient, reliable setup

Fully customisable by smartphone via Bluetooth using a TA-Dongle.

Fully configurable

More than 200 setup options allow input and output signals, binary input, relay, characteristics and many other parameters to be configured.

Easy diagnostics

Tracks the last 10 errors to allow system faults to be found quickly.

Quick copying of settings

Setup configuration can be copied quickly from the TA-Dongle to identical TA-Slider actuators.

Technical description

Functions:

Proportional control
 Manual override (TA-Dongle)
 Stroke detection
 Mode, status and position indication
 Stroke limitation setting
 Minimum stroke setting
 Valve blockage protection
 Valve clogging detection
 Error safe position
 Diagnostic/Logging
 Delayed start-up

BACnet/Modbus version:

+ 1 binary input, max. 100 Ω , cable max. 10 m or shielded.
 + 2 connections for Pt1000 temperature probe.

BACnet/Modbus R24 version:

+ 1 binary input, max. 100 Ω , cable max. 10 m or shielded.
 + 2 connections for Pt1000 temperature probe.
 + 1 relay, max. 2A, 30 VAC/VDC on resistive load.

Supply voltage:

24 VAC/VDC $\pm 15\%$.
 Frequency 50/60 Hz ± 3 Hz.

Power consumption:

Operation: < 3.0 VA (VAC); < 1.5 W (VDC)
 Standby: < 1.5 VA (VAC); < 0.75 W (VDC)

Input signal:

By BACnet/Modbus or with hybrid control mode;
 0(2)-10 VDC, R_i 47 k Ω .
 Adjustable hysteresis sensitivity 0.1-0.5 VDC.
 0.33 Hz low pass filter.
 Proportional:
 0-10, 10-0, 2-10 or 10-2 VDC
 Proportional split-range:
 0-5, 5-0, 5-10 or 10-5 VDC.
 0-4.5, 4.5-0, 5.5-10 or 10-5.5 VDC.
 2-6, 6-2, 6-10 or 10-6 VDC.
 Proportional dual-range (for change-over):
 0-3.3 / 6.7-10 VDC,
 2-4.7 / 7.3-10 VDC,
 0-4.5 / 5.5-10 VDC or
 2-5.5 / 6.5-10 VDC.
 Default setting: By BACnet/Modbus.
 If Hybrid mode chosen, default input signal is Proportional 0-10 VDC.

Output signal:

By BACnet/Modbus.

Characteristics:

Linear, EQM 0.25 and inverted EQM 0.25.
 Default setting: Linear.

Control speed:

4 or 6 s/mm.
 Default setting: 4 s/mm.

Adjusting force:

Push 500 N
 Pull 300 N

Temperature:

Media temperature: max. 120°C
 Operating environment: 0°C – +50°C (5-95%RH, non-condensing)
 Storage environment: -20°C – +70°C (5-95%RH, non-condensing)

Ingress protection:

IP54 (all directions)
 (according to EN 60529)

Protection class:

(according to EN 61140)
 III (SELV)

Cables:

Separate overmoulded cables (see Additional equipment).
Type LiYCY 5x0.34 mm² (cables A and B) and type LiYY 6x0.34 mm² (cable C).
Halogen free, fire class B2_{ca} – s1a, d1, a1 according to EN 50575.
Relay cable (R24 version):
Type LiYY 3x0.34 mm².
1, 2 or 5 m. With wire end sleeves.
Halogen free, fire class B2_{ca} – s1a, d1, a1 according to EN 50575.

Stroke:

16,2 mm.
Automatic detection of the valve lift (stroke detection).

Noise level:

Max. 30 dBA

Weight:

BACnet/Modbus: 0.25 kg
BACnet/Modbus R24:
0.29 kg, 1 m relay cable
0.33 kg, 2 m relay cable
0.47 kg, 5 m relay cable

Connection to valve:

Swivelling nut M30x1,5.

Material:

Cover: PC/ABS GF8
Housing: PA GF40.
Swivelling nut: Nickel-plated brass.

Colour:

White RAL 9016, grey RAL 7047.

Marking:

Label: IMI TA, CE, product name, article No. and technical specification.

Certification CE:

LV-D. 2014/35/EU: EN 60730-1, -2-14.
EMC-D. 2014/30/EU: EN 60730-1, -2-14.
RoHS-D. 2011/65/EU: EN 63000.

Product standard:

EN 60730.

Function

Setting

The actuator can be set by the HyTune app (iOS version 8 or later on iPhone 4S or later, Android version 4.3 or later) + the TA-Dongle device, with or without the actuator power supplied. The setting configuration can be stored in the TA-Dongle for setting of one or several actuators. Connect the TA-Dongle to the actuator and press the configuration button. HyTune can be downloaded from the App Store or Google Play.

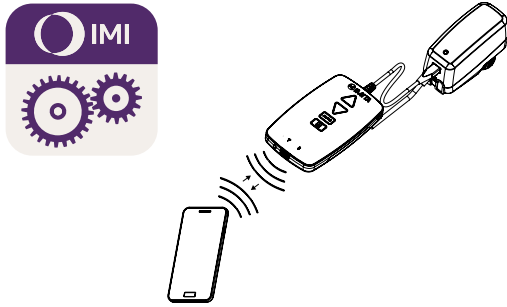

Manual override

By using the TA-Dongle device. No power supply needed.

Calibration/Stroke detection

According to selected settings in the table.

Type of calibration	At power on	After manual override
Both end positions (full)	√ *	√
Fully extended position (fast)	√	√ *
None	√	

*) Default

Note: A calibration refresh can be automatically repeated monthly or weekly.
Default setting: Off.

Stroke limitation setting

A maximum stroke smaller than or equal to the detected valve lift can be set to the actuator.

For some IMI TA/IMI Heimeier valves it can also be set to a

Kv_{max}/q_{max} .

Default setting: No stroke limitation (100%).

Minimum stroke setting

The actuator can be set with a minimum stroke below which it will not go (except for calibration).

For some IMI TA/IMI Heimeier valves, it can also be set to a q_{min} .

Default setting: No minimum stroke (0%).

Valve blockage protection

The actuator will perform a quarter of a full stroke and then back to desired value if no actuation takes place for one week or one month.

Default setting: Off.

Valve clogging detection

If actuation stops before the desired value is reached, the actuator moves back ready to make a new attempt. The actuator will move to the configured error safe position after three attempts.

Default setting: On.

Error safe position

Fully extended or retracted position when following errors occur; low power, line break, valve clogging or stroke detection failure.

Default setting: Fully extended position.

Diagnostics/logging

The last 10 errors (low power, line break, valve clogging, stroke detection failure) with time stamps can be read using the HyTune app + TA-Dongle device. Logged errors will be cleared if the power is disconnected.

Delayed start-up

The actuator can be specified a delay (0 to 1275 sec.) before starting up after a power supply cut. This is useful when used with a control system that has itself a long start-up time.

Default setting: 0 seconds.

Binary input

If the binary input circuit is open, the actuator will go to a set stroke, switch to a second stroke limitation setting or drive to its full stroke regardless of any limitations for flushing purpose. See also Change-over system detection.

Default setting: Off

Change-over system detection

Switching between two different stroke limitation settings by toggling the binary input, using the dual-range input signal or performing the switching via BACnet or Modbus.

BACnet/Modbus and BACnet/Modbus R24 versions:

BACnet MS/TP (BACnet Protocol Revision 14).

Modbus RTU.

More detailed information, please see TA-Slider 160/500 BACnet MS/TP and Modbus RTU protocol implementation documents.

LED indication

LED indication

		Status	Red (heating) / Blue (cooling)
	— — — —	Fully retracted (actuator stem)	Long pulse - Short pulse
	— — — —	Fully extended (actuator stem)	Short pulse - Long pulse
	— — — —	Intermediate position	Long pulses
	— — — —	Moving	Short pulses
	— — — —	Calibrating	2 short pulses
		Manual mode or no power supply	Off

		Error code	Violet
	- - -	Power supply too low	1 pulse
	- - -	Line broken (2-10 V)	2 pulses
	- - -	Valve clogging or foreign object	3 pulses
	- - -	Stroke detection failure	4 pulses

If an error is detected, violet pulses are displayed as the red or blue status lights flash alternately. More detailed information, please see the HyTune app + TA-Dongle.

Bus LED indication

Colour	Status
Red	Change of network configuration or board starting
Orange	Message received
Green	Ready - Waiting for messages

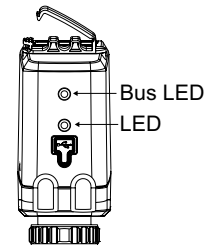

Installation

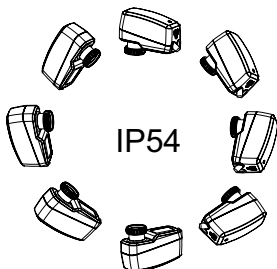

Note!

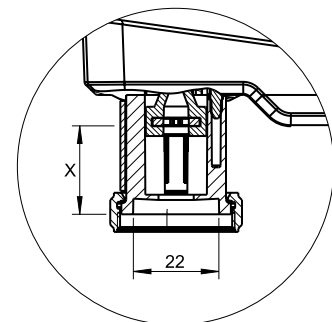
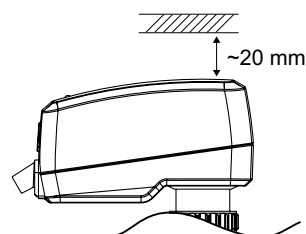

X = 7.7 - 23.9 mm

Connection diagram – BACnet/Modbus

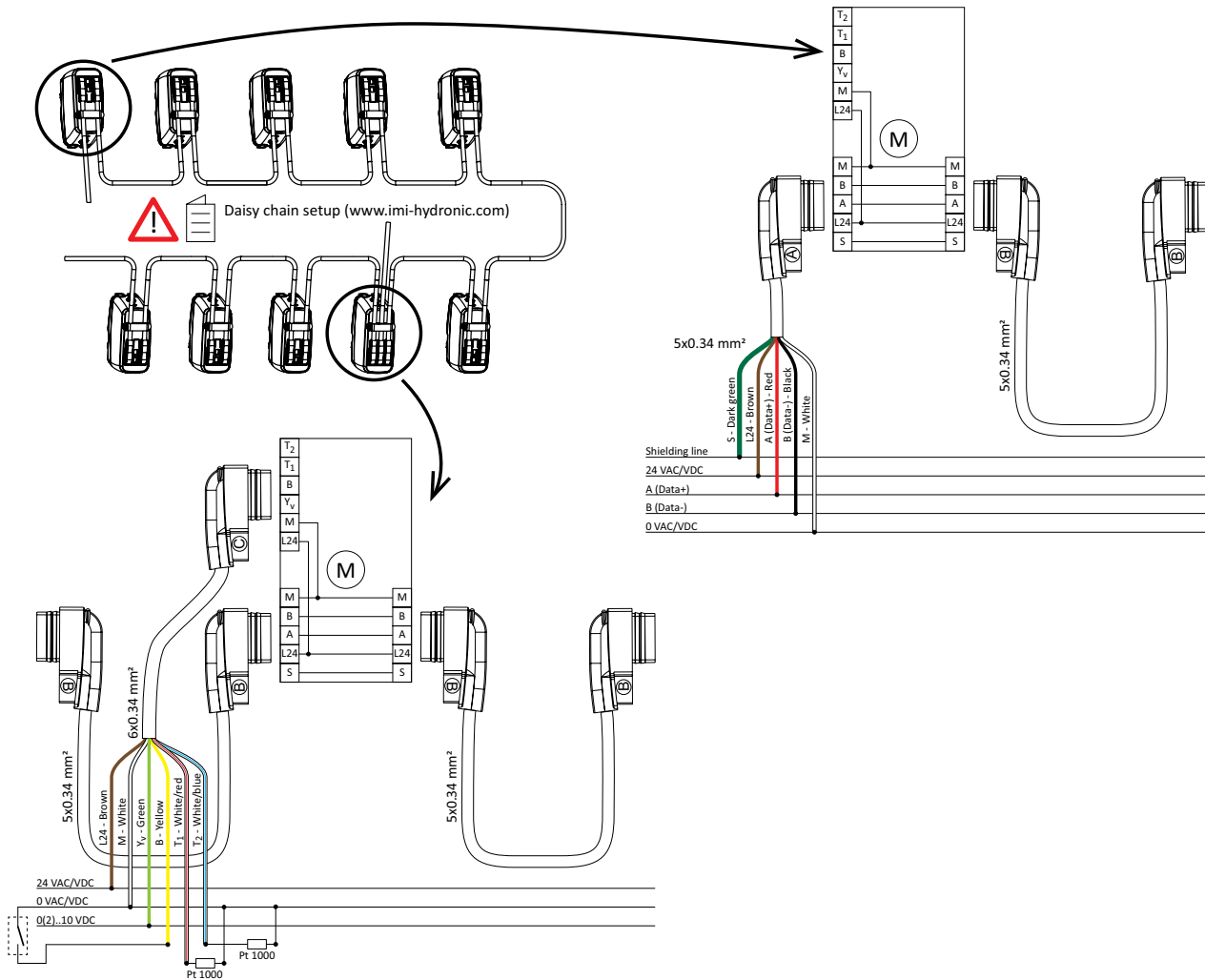

Terminal	Description
S	Shielding, line should be connected at one end to a specific shielding terminal connected itself to EARTH.
L24	Power supply 24 VAC/VDC
M	Neutral for power supply 24 VAC/VDC and signals.
A (Data+)	Data+ (RS 485)
B (Data-)	Data- (RS 485)
Y _v	Input signal for proportional control 0(2)-10 VDC, 47 kΩ.
B	Connection for potential free contact (e.g. open window detection), max. 100 Ω, max. 10 m cable or shielded.
T1	Connection for Pt1000 temperature sensor, to be connected between T1 and M, max. 10 m total cable length between actuator and sensor head.
T2	Second connection for Pt1000 temperature sensor, to be connected between T2 and M, max. 10 m total cable length between actuator and sensor head.



24 VAC/DC operating only with safety transformer according to EN 61558-2-6.

Connection diagram – BACnet/Modbus R24

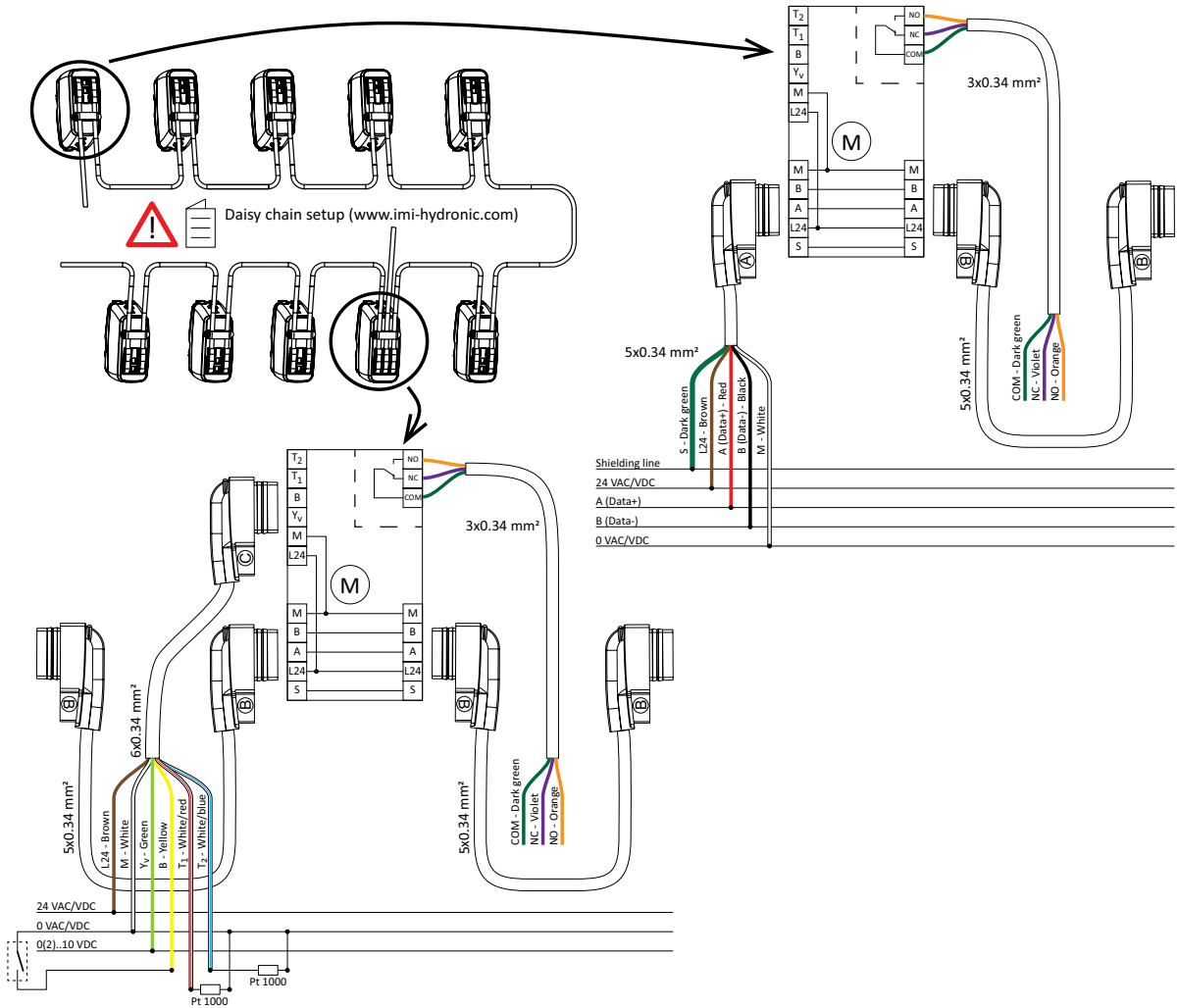

Terminal	Description
S	Shielding, line should be connected at one end to a specific shielding terminal connected itself to EARTH.
L24	Power supply 24 VAC/VDC
M	Neutral for power supply 24 VAC/VDC and signals.
A (Data+)	Data+ (RS 485)
B (Data-)	Data- (RS 485)
Y _v	Input signal for proportional control 0(2)-10 VDC, 47 kΩ.
B	Connection for potential free contact (e.g. open window detection), max. 100 Ω, max. 10 m cable or shielded.
T1	Connection for Pt1000 temperature sensor, to be connected between T1 and M, max. 10 m total cable length between actuator and sensor head.
T2	Second connection for Pt1000 temperature sensor, to be connected between T2 and M, max. 10 m total cable length between actuator and sensor head.
COM	Common contact of relay, max. 2A @ 30 VAC/VDC on resistive load
NC	Normally closed contact for relay
NO	Normally open contact for relay



24 VAC/DC operating only with safety transformer according to EN 61558-2-6.

Daisy chain setup

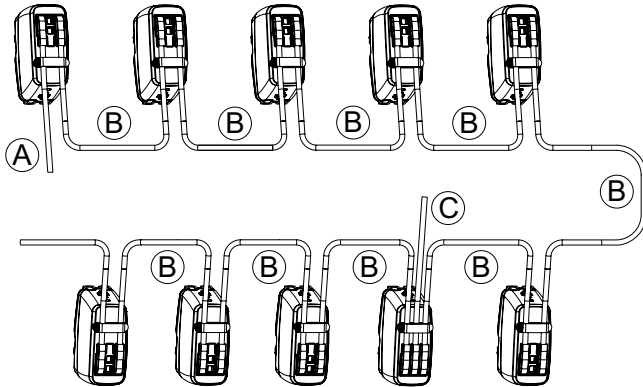

A: To connect the first TA-Slider 160/500 BACnet or Modbus of a daisy chain to the Bus.

B: Between two actuators in a daisy chain.

C: To enable hybrid mode or provide power supply if the daisy chain is long.

Max. number* of TA-Slider in a daisy chain, before power boosting is required (cable C).

Using DC voltage increases the max. number of devices (not possible for CO option as TA-M106 requires 24 VAC).

	24 VDC	24 VAC
TA-Slider 160 BACnet/Modbus	17	14
TA-Slider 160 BACnet/Modbus CO	n.a.	8
TA-Slider 500 BACnet/Modbus	14	10
TA-Slider 500 BACnet/Modbus R24	14	10

* Assuming strictly 24 V at the free wire end of the first daisy chain cable (power supply output). For other start voltages, please contact IMI.

Articles - BACnet/Modbus

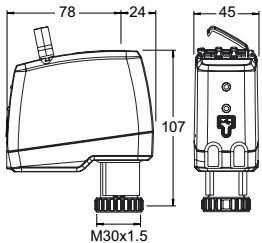

TA-Slider 500 BACnet/Modbus

Input signal: Via Bus or 0(2)-10 VDC

With binary input and 2 connections for Pt1000 temperature probe

	Bus	EAN	Article No
	BACnet	5901688824009	322225-13011
	Modbus	5901688823781	322225-12011

Articles - BACnet/Modbus R24

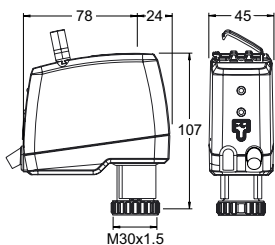

TA-Slider 500 BACnet/Modbus R24

Input signal: Via Bus or 0(2)-10 VDC

With binary input, 2 connections for Pt1000 temperature probe and relay 24V

Relay cable length [m]	Bus	EAN	Article No
With halogen free relay cable			
1	BACnet	5901688829059	322225-13314
2	BACnet	5901688829066	322225-13315
5	BACnet	5901688829073	322225-13316
1	Modbus	5901688824092	322225-12314
2	Modbus	5901688824108	322225-12315
5	Modbus	5901688824115	322225-12316

Additional equipment

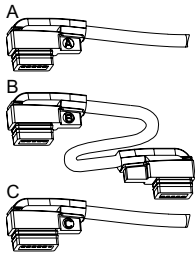

Daisy chain cables

A: To connect the first TA-Slider 160/500 BACnet or Modbus of a daisy chain to the Bus.

B: Between two actuators in a daisy chain.

C: To enable hybrid mode or provide power supply if the daisy chain is long.

Cable length [m]	EAN	Article No
Halogen free cable		
Type A		
1,5	5902276898228	322042-80012
5	5902276898235	322042-80013
10	5902276898242	322042-80014
Type B		
1,5	5902276898259	322042-80015
5	5902276898266	322042-80016
10	5902276898273	322042-80017
Type C		
1,5	5902276898280	322042-80018
5	5902276898297	322042-80019
10	5902276898303	322042-80020

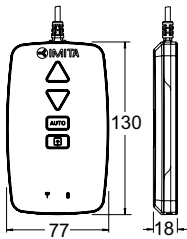

TA-Dongle

For Bluetooth communication with the HyTune app, transfer configuration settings and manual override.

EAN	Article No
5901688828632	322228-00001



The products, texts, photographs, graphics and diagrams in this document may be subject to alteration by IMI without prior notice or reasons being given. For the most up to date information about our products and specifications, please visit climatecontrol.imiplc.com.