

Climate
Control

IMI TA

STAP



Differential pressure controllers

DN 65-100, adjustable set-point and shut-off function

STAP

The flanged STAP is a high-performing differential pressure controller that keeps the differential pressure over the load constant. This delivers accurate and stable modulating control, ensures less risk of noise from control valves, and results in easy balancing and commissioning. STAP's unrivalled accuracy and compact size make it particularly suitable for use on the secondary side of heating and cooling systems.



Key features

Adjustable set-point

Delivers desired differential pressure ensuring accurate balancing.

Measuring points

Simplifies the balancing procedure, and increases its accuracy.

Shut-off function

Shut-off function makes maintenance easy and straightforward.

Technical description

Application:

Heating and cooling systems.

Temperature:

Max. working temperature: 120°C
Min. working temperature: -10°C

Surface treatment:

Valve body: Epoxy painting.

Functions:

Differential pressure control
Adjustable Δp
Measuring points
Shut-off

Media:

Water or neutral fluids, water-glycol mixtures (0-57%).

Marking:

Body: TA, PN 16, DN, CE, 250 CI, flow arrow and casting date (year, month, day).

Bonnet and handwheel: Label with STAP, DN, Δp L 20-80 resp 40-160 kPa and bar code.

Dimensions:

DN 65-100

Material:

Valve body: Cast iron EN-GJL-250 (GG 25)
Bonnet: AMETAL®
Cone: PTFE coated AMETAL®
Spindles: AMETAL®
O-rings: EPDM rubber
Seat seal: Plug with EPDM O-ring
Membrane: Reinforced EPDM rubber
Spring: Stainless steel
Handwheel: Polyamide

Face to face dimensions:

ISO 5752 series 1, BS 2080

Pressure class:

PN 16

Flanges:

ISO 7005-2.

Max. differential pressure (Δp_V):

350 kPa

Setting range:

20* - 80 kPa resp 40* - 160 kPa.

*) Delivery setting

AMETAL® is the dezincification resistant alloy of IMI.

Operating instruction

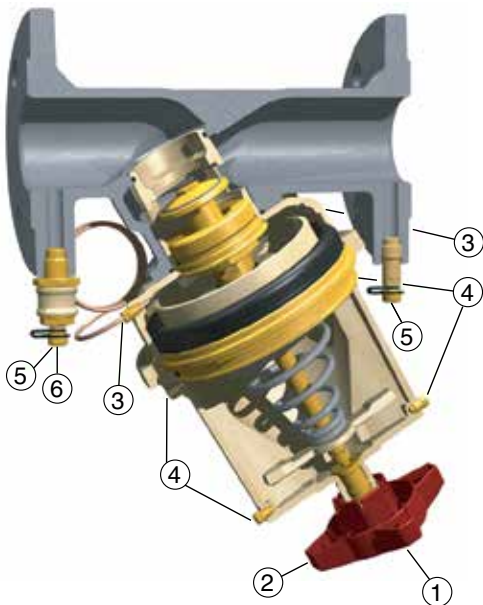

1. Setting ΔpL (5 mm allen key)
2. Shut-off
3. Connection capillary pipe, low pressure.
4. Venting.
Connection measuring point STAP.
Connection capillary pipe, high pressure.
5. Measuring point
6. Opening/closing of measure signal for the low pressure side

Measuring point

Remove the cover and then insert the probe through the self-sealed measuring point.

Measuring point STAP (accessory) can be connected to the venting if the STAF valve is out of reach when measuring the differential pressure.

Capillary pipe

When extending the capillary pipe, use e.g. 6 mm copper pipe and extension kit (accessory).

Note! The supplied capillary pipe must be included.

Installation

Note! The STAP must be placed in the return pipe and with correct flow direction.

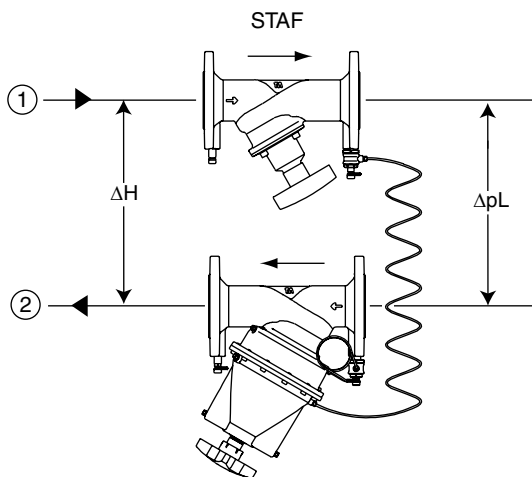

1. Inlet
2. Return

For installation examples, see Handbook No 4 - Hydronic balancing with differential pressure controllers.
STAF – see catalogue leaflet “STAF, STAF-SG”.

Sizing

The diagram shows the lowest pressure drop required for the STAP valve to be within its working range at different flows.

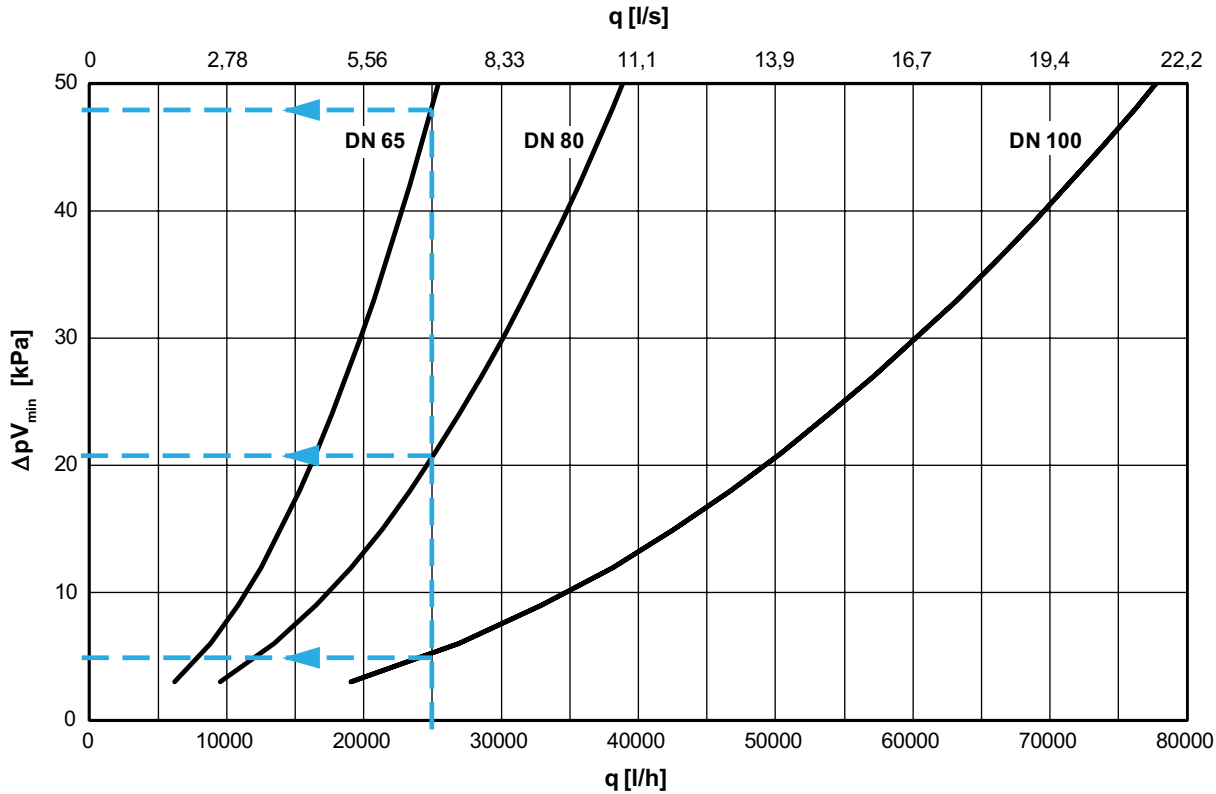

Example:

Design flow 25 000 l/h, $\Delta pL = 34$ kPa and available differential pressure $\Delta H = 85$ kPa.

1. Design flow (q) 25 000 l/h.

2. Read the pressure drop ΔpV_{min} from the diagram.

$$\begin{aligned} \text{DN 65 } \Delta pV_{min} &= 48 \text{ kPa} \\ \text{DN 80 } \Delta pV_{min} &= 21 \text{ kPa} \\ \text{DN 100 } \Delta pV_{min} &= 5 \text{ kPa} \end{aligned}$$

3. Check that the ΔpL is within the setting range for these sizes.

4. Calculate required available differential pressure ΔH_{min} .

At 25 000 l/h and fully open STAF the pressure drop is, DN 65 = 9 kPa, DN 80 = 4 kPa and DN 100 = 2 kPa.

$$\Delta H_{min} = \Delta pV_{STAF} + \Delta pL + \Delta pV_{min}$$

$$\begin{aligned} \text{DN 65: } \Delta H_{min} &= 9 + 34 + 48 = 91 \text{ kPa} \\ \text{DN 80: } \Delta H_{min} &= 4 + 34 + 21 = 59 \text{ kPa} \\ \text{DN 100: } \Delta H_{min} &= 2 + 34 + 5 = 41 \text{ kPa} \end{aligned}$$

5. In order to optimise the control function of the STAP select the smallest possible valve, in this case DN 80. (DN 65 is not suitable since $\Delta H_{min} = 91$ kPa and available differential pressure 85 kPa only).

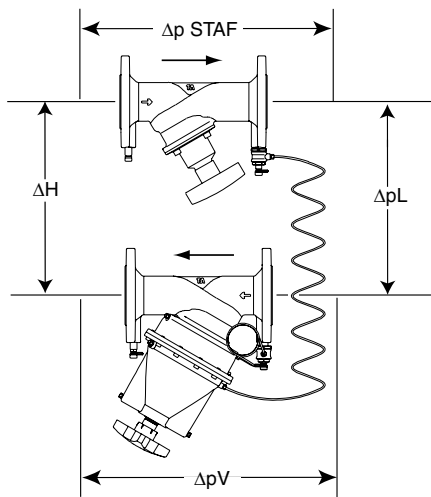

$$\Delta H = \Delta pV_{STAF} + \Delta pL + \Delta pV$$

IMI recommends the software HySelect for calculating the STAP size. HySelect can be downloaded from climatecontrol.imiplc.com.

Working range

	Kv_{min}	Kv_{nom}	Kv_m	q_{max} [m ³ /h]
DN 65	1,4	25	36	25,5
DN 80	2,2	38	55	38,9
DN 100	4,4	77	110	77,8

Kv_{min} = m³/h at a pressure drop of 1 bar and minimum opening corresponding to the p-band (+25%).

Kv_{nom} = m³/h at a pressure drop of 1 bar and opening corresponding to the middle of the p-band (ΔpL_{nom}).

Kv_m = m³/h at a pressure drop of 1 bar and maximum opening corresponding to the p-band (-25%).

Note! The flow in the circuit is determined by its resistance, i.e. Kv_C :

$$q_C = Kv_C \sqrt{\Delta p l}$$

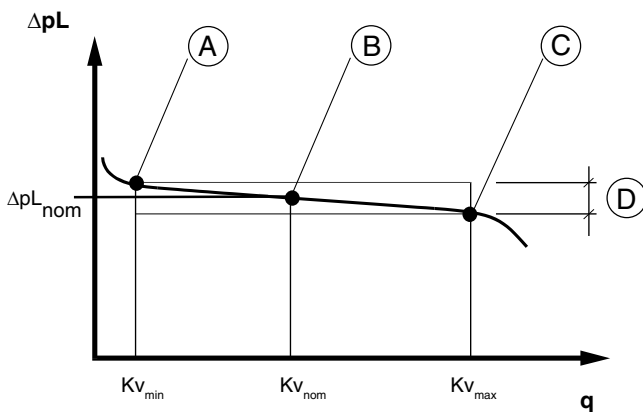

- A. Kv_{min}
- B. Kv_{nom} (Delivery setting)
- C. Kv_m
- D. Working range $\Delta pL_{nom} \pm 25\%$

Application examples

Stabilising the differential pressure across a riser with balancing valves (“Modular valve method”)

The “Modular valve method” is suitable when a plant is put into operation phase by phase. Install one differential pressure controller on every riser, so that each STAP controls one module.

STAP keeps the differential pressure from the main pipe at a stable value out to the risers and circuits. STAD(STAF) downstream on the circuits guarantees that overflows do not occur. With STAP working as a modular valve, the whole plant does not need to be re-balanced when a new module is taken into operation. There is no need for balancing valves on the main pipes (except for diagnostic purposes), since the modular valves distribute the pressure out to the risers.

- STAP reduces a big and variable ΔH to a suitable and stable Δp_L .
- The set Kv-value in STAD(STAF) limits the flow in each circuit.
- STAF is used for flow measuring, shut-off and connection of the capillary pipe.

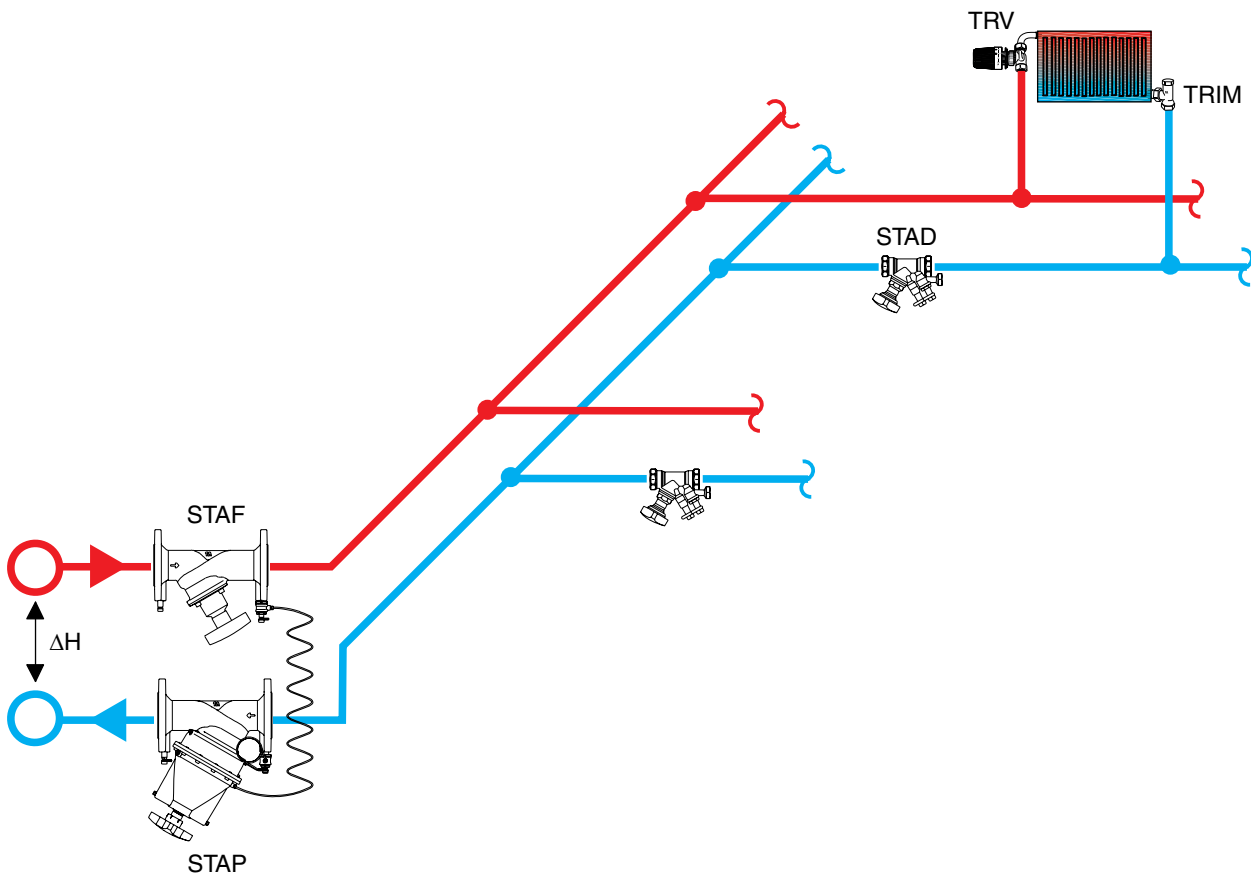

Articles

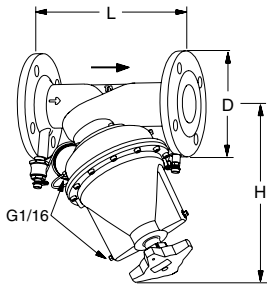

Flanged

1 m capillary pipe and transition nipple with shut-off are included.

PN 16, ISO 7005-2

DN	Number of bolt holes	D	L	H	Kv _m	q _{max} [m ³ /h]	Kg	EAN	Article No
20-80 kPa									
65	4	185	290	321	36	25,5	22	7318793750402	52 265-065
80	8	200	310	337	55	38,9	24	7318793750600	52 265-080
100	8	220	350	350	110	77,8	29	7318793750808	52 265-090
40-160 kPa									
65	4	185	290	321	36	25,5	22	7318793750501	52 265-165
80	8	200	310	337	55	38,9	24	7318793750709	52 265-180
100	8	220	350	350	110	77,8	29	7318793750907	52 265-190

→ = Flow direction

Kv_m = m³/h at a pressure drop of 1 bar and maximum opening corresponding to the p-band (-25%).

Accessories

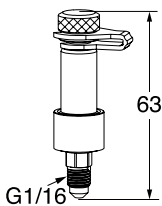

Measuring point STAP

EAN

Article No

7318793660602

52 265-205

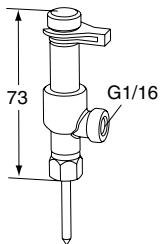

Measuring point, two-way

For connection of capillary pipe while permitting simultaneous use of our balancing instrument.

EAN

Article No

7318793784100

52 179-200

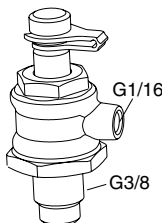

Capillary pipe connection with shut-off

EAN

Article No

7318793781604

52 265-206

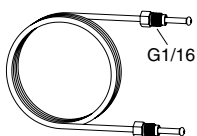

Capillary pipe

L

EAN

Article No

1 m

7318793661500

52 265-301

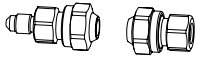

Extension kit for capillary pipe
 Complete with connections for 6 mm
 pipe

EAN	Article No
7318793781505	52 265-212

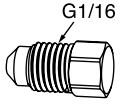

Plug
 Venting

EAN	Article No
7318793661609	52 265-302