

**Climate
Control**

IMI Heimeier

Calypso exact



Thermostatic Radiator Valves
With stepless precision presetting

Calypso exact

Calypso exact thermostatic valve bodies are used in two-pipe warm water pump heating systems with normal to high temperature spread. The integrated stepless precision presetting makes precise hydraulic balancing possible with the aim of providing all heat consumers with hot water according to their heat requirements. The valve has a large flow range and is characterized by an optimized noise performance and very low flow tolerances.



Key features

Optimised noise behaviour

Through specially designed setting

High flow range

For various applications

Double O-ring seal

For durable and maintenance free operation

Technical description

Applications:

Heating systems

Function:

Control
Stepless presetting
Shut-off

Dimensions:

DN 10-20

Pressure class:

PN 10

Temperature:

Max. working temperature: 120°C, with protection cap or actuator 100°C.
Min. working temperature: 2°C.

Materials:

Valve body: Brass
O-rings: EPDM rubber
Valve disc: EPDM rubber
Return spring: Stainless steel
Valve insert: Brass, PPS (polyphenylsulphide) and SPS (syndiotactic polystyrene)
The complete thermostatic insert can be replaced using the IMI Heimeier fitting tool without draining the system.
Spindle: Niro-steel spindle with double O-ring sealing.

Surface treatment:

Valve body and fittings are nickel-plated.

Marking:

THE, country code, flow direction arrow, DN and KEYMARK-Designation. II+ Designation.
White protection cap.

Standards:

Calypso exact valves meet the following requirements:
– KEYMARK certified and tested to DIN EN 215, serie F.
– the “highly expanded version” and the “standard version” of the specification FW 507 drawn up by the Arbeitsgemeinschaft Fernwärme (AGFW) (Working Group for District Heating).



Pipe connection:

The internal-threaded version is designed for connection to threaded pipe, or in conjunction with compression fittings, to copper or precision steel pipe. With double connection fitting suitable for compression fitting for multi layer pipes.

Connection to thermostatic head and actuator:

IMI Heimeier M30x1,5

Construction

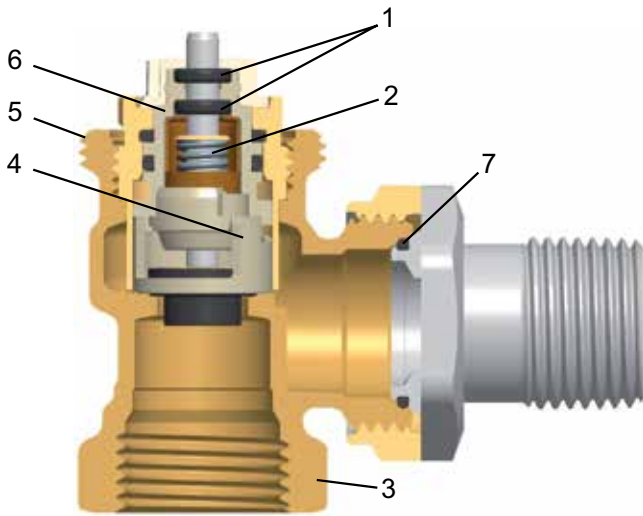

1. Long-life double O-ring sealing.
2. Strong return spring in combination with high locating force ensures that the valve does not slacken off over time.
3. Valve body made of brass
4. Precise regulating part for accurate stepless presetting.
5. IMI Heimeier M30x1.5 connection technology.
6. Valve insert replaceable using the fitting tool without draining the system.
7. EPDM O-ring

Application

The thermostatic valve body Calypso exact is applied in two-pipe pumped hot-water heating system with normal to high temperature spread. The valve has a wide flow range as well as optimised noise behaviour and very tight flow tolerances. In extensive systems, even water distribution should be maintained not only during specified normal operation, but also after a drop in room temperature or a break in operations, in order to avoid under or over-supply to parts of the system. To achieve this, the valve characteristic is designed so that the radiator mass-flow does not exceed about 1.3 times the nominal flow even at Preset 8 and with a fully-open valve.

Corresponding to the standards EnEV and DIN V 4701-10, Calypso exact thermostatic valve bodies can be designed with a p-band of up to max. 1 K or max. 3 K.

Optimized flow restriction

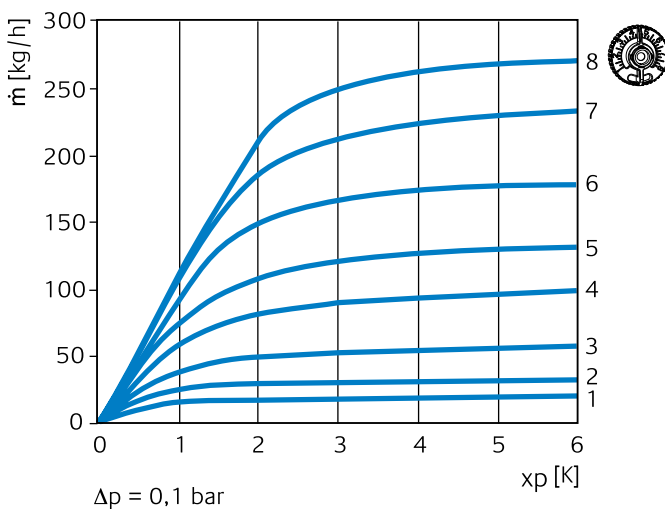

Lowest flow tolerances

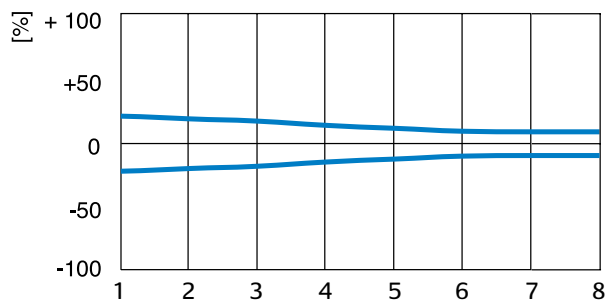

Noise behaviour

To ensure low-noise performance, the following conditions must be met:

- On the basis of experience, the differential pressure over the thermostatic valves should not exceed about 20 kPa = 200 mbar = 0.2 bar. If in designing the system, higher transient differentials might be experienced in the part-load flow range, differential pressure control equipment such as a STAP Differential Pressure Controller or Hydrolux bypass valves can be used (see diagram for noise characteristic curve).
- Mass-flow must be correctly adjusted.
- The system must be completely deaerated.

Sample application

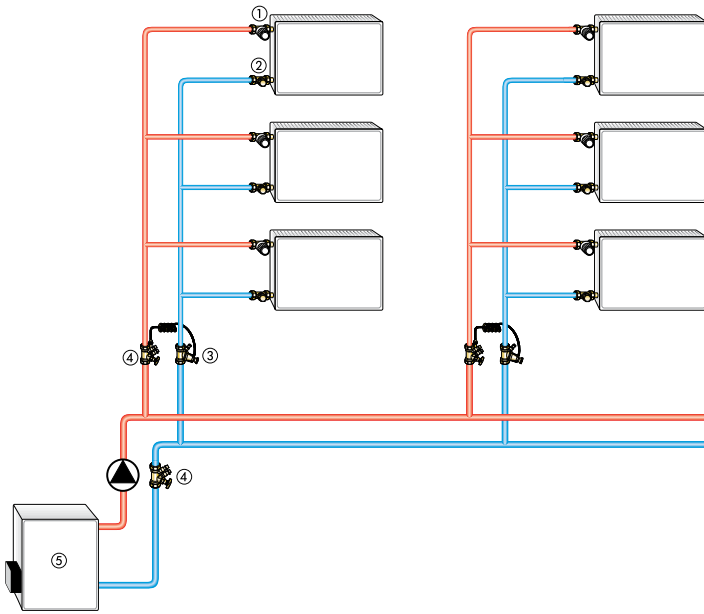

1. Calypso exact thermostatic valve body
2. Regutec lockshield
3. STAP differential pressure controller
4. STAD balancing valve
5. Boiler

Notes

- To avoid damage and the formation of scale deposit in the hot-water heating system, the composition of the heat transfer medium should be in accordance with the VDI guideline 2035. For industrial and long-distance energy systems, see the applicable codes VdTÜV and 1466/AGFW FW 510. A heat transfer medium containing mineral oils, or any type of lubricant containing mineral oil can have extremely negative effects and usually lead to the disintegration of EPDM seals. When using nitrite-free frost and corrosion resistance solutions with an ethylene glycol base, pay close attention to the details outlined in the manufacturers' documentation, particularly concerning concentration and specific additives.
- Flush the system before changing thermostatic valves in heavy polluted existing systems.
- The thermostatic valve bodies can be used with all IMI Heimeier thermostatic heads and IMI Heimeier or IMI TA thermal actuators or motorized. The optimal tuning of the components guarantees maximum safety. When using actuators from other manufacturers, make sure that the pressure power is appropriate for thermostatic valve bodies with soft sealing valve discs.

Operation

Presetting

The presetting can be selected steplessly between 1 and 8. There are 7 additional marks between the preset values, thus enabling exact setting. Setting 8 corresponds to the standard setting (factory setting). The technician can undertake or change the setting with the setting key or spanner (13 mm). This ensures unauthorised persons cannot tamper with the setting.

- Plug the setting key or universal key into the valve insert and turn until it engages in position.
- Turn the index of the desired setting value to the index figure of the valve insert.
- Withdraw the key. The setting on the valve insert is visible from the actuating direction (see fig.).

Front-end visibility

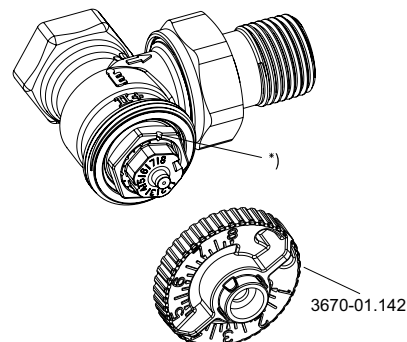

*) Index

Technical data

Diagram, valve body with thermostatic head
P-band [xp] 1.0 K

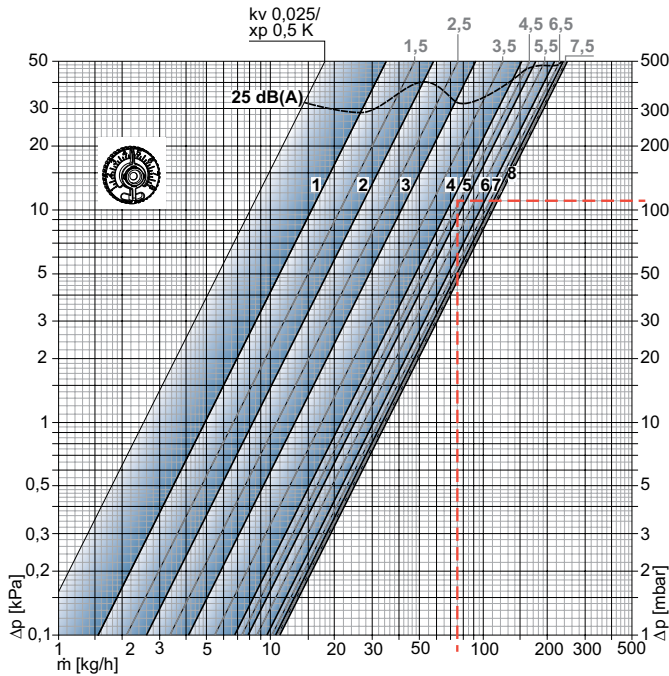

P-band [xp] 2.0 K

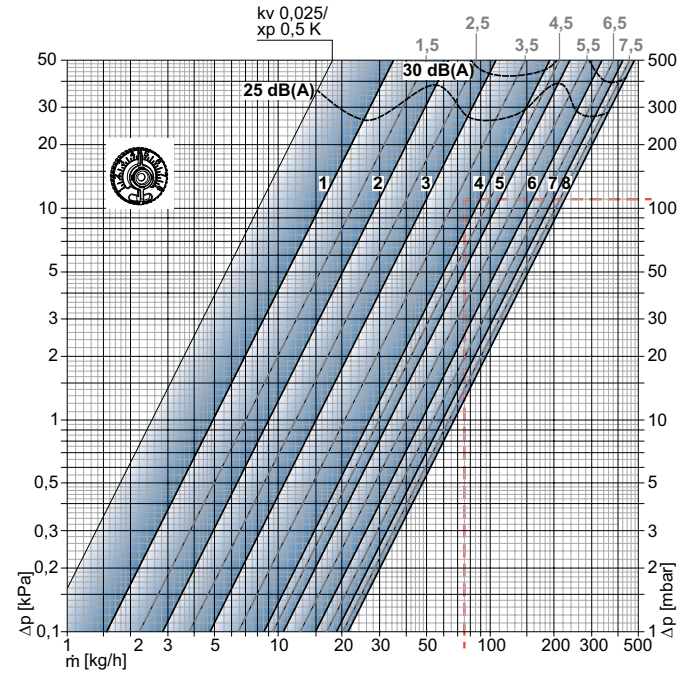

Valve body (DN 10/15/20) with thermostatic head

		Presetting								Permitted differential pressure, during which the valve is kept closed Δp [bar]	
		1	2	3	4	5	6	7	8	Th.-head	EMO T/TM EMOtec TA-TRI TA-Slider 160
P-band [xp] 1.0K	kv-value	0,049	0,082	0,130	0,215	0,246	0,303	0,335	0,343	1,0	3,5
P-band [xp] 2.0K	kv-value	0,049	0,090	0,150	0,265	0,330	0,470	0,590	0,670		
	Kvs	0,049	0,102	0,185	0,313	0,420	0,565	0,740	0,860		
	Flow tolerance ± [%]	20	18	16	14	12	10	10	10		

$Kv/Kvs = m^3/h$ at a pressure drop of 1 bar.

Sample calculation

Target:

Setting range

Given:

Heat flow $Q = 1308 \text{ W}$

Temperature spread $\Delta T = 15 \text{ K}$ (65/50 °C)

Pressure loss, thermostatic valve $\Delta pV = 110 \text{ mbar}$

Solution:

Mass flow $m = Q / (c \cdot \Delta T) = 1308 / (1,163 \cdot 15) = 75 \text{ kg/h}$

Setting range from Diagram:

With P-band **max. 1.0 K**: 4,5

With P-band **max. 2.0 K**: 4

$$Cv = \frac{Kv}{0,86}$$

$$Kv = Cv \cdot 0,86$$

Presetting table

Presetting values for various radiator performances, pressure drops, and system spread

Q [W]		200	250	300	400	500	600	700	800	900	1000	1200	1400	1600	1800	2000	2200	2400	2600	2800	3000	3200	3400	3600	3800	4000	4800	5300	6500	6800	8400	9000	12000																								
Δt [K]	Δp [kPa]																																																								
10	5	2	3	3	4	4	4	5	5	6	6	6	7	8																																											
	10	2	2	2	3	3	4	4	4	4	5	5	6	6	7	7	8	8																																							
	15	2	2	2	3	3	3	4	4	4	4	5	5	6	6	6	7	7	8	8																																					
15	5	2	2	2	3	3	4	4	4	4	4	5	6	6	6	7	7	7	8																																						
	10	1	1	2	2	3	3	3	3	4	4	4	4	5	5	6	6	6	7	7	7	7	8	8																																	
	15	1	1	1	2	2	3	3	3	3	3	4	4	4	5	5	5	6	6	6	6	7	7	7	7	8																															
20	5	1	1	2	2	3	3	3	4	4	4	4	5	5	6	6	6	6	7	7	7	8	8																																		
	10	1	1	1	2	2	2	3	3	3	3	4	4	4	4	5	5	5	6	6	6	6	6	7	7	7	8																														
	15	1	1	1	2	2	2	3	3	3	3	4	4	4	4	4	5	5	5	6	6	6	6	6	6	7	8																														
40	5	1			1	1	2	2	2	2	3	3	3	4	4	4	4	4	4	5	5	5	5	6	6	6	6	7	8	8																											
	10	1			1	1	1	2	2	2	2	3	3	3	3	4	4	4	4	4	4	4	4	5	5	5	6	6	6	7	7																										
	15	1			1	1	1	2	2	2	2	2	3	3	3	3	3	4	4	4	4	4	4	4	4	4	4	4	4	5	5	6	6	7	8																						

10 kPa = 100 mbar = 1 mWS

Presetting value at max. 2 K P-band.

Q = radiator performance

ΔT = system spread

Δp = Differential pressure

Example:

Q = 1000 W, ΔT = 15 K, Δp = 10 kPa

Presetting value: **4**

Tips:

For an approximate determination of the preset for given radiator performance and system spread, an average differential pressure of 10 kPa is recommended.

For systems that are widely extended horizontally, a differential pressure drop is necessary:

eg, 15 kPa for valves near the central unit, 10 kPa for valves at a medium range, and 5 kPa for valves on remote radiators.

An exact determination can only be carried out by making a pipe network calculation using the diagram, or with a calculation program.

Articles

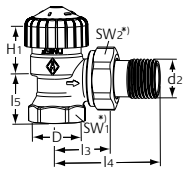

Angle

DN	D	d2	I3	I4	I5	H1	Kv p-band max. 2 K	Kvs	EAN	Article No
10	Rp3/8	R3/8	24	49	20	24	0,025 - 0,670	0,86	4024052923014	3451-01.000
15	Rp1/2	R1/2	26	53	23	23,5	0,025 - 0,670	0,86	4024052922918	3451-02.000
20	Rp3/4	R3/4	30	63	26	21,5	0,025 - 0,670	0,86	4024052927814	3451-03.000

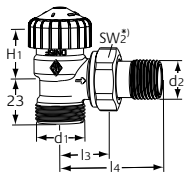

Angle

with external thread G 3/4

DN	d1	d2	I3	I4	H1	Kv p-band max. 2 K	Kvs	EAN	Article No
15	G3/4	R1/2	26	53	23,5	0,025 - 0,670	0,86	4024052949311	3455-02.000

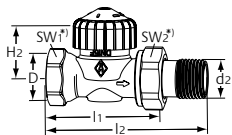

Straight

DN	D	d2	I1	I2	H2	Kv p-band max. 2 K	Kvs	EAN	Article No
10	Rp3/8	R3/8	50	76	22,5	0,025 - 0,670	0,86	4024052926817	3452-01.000
15	Rp1/2	R1/2	55	83	22,5	0,025 - 0,670	0,86	4024052926916	3452-02.000
20	Rp3/4	R3/4	65	97	22,5	0,025 - 0,670	0,86	4024052927913	3452-03.000

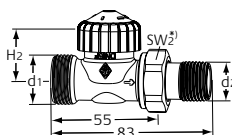

Straight

with external thread G 3/4

DN	d1	d2	H2	Kv p-band max. 2 K	Kvs	EAN	Article No
15	G3/4	R1/2	22,5	0,025 - 0,670	0,86	4024052949410	3456-02.000

*) SW1: DN 10 = 22 mm, DN 15 = 27 mm, DN 20 = 32 mm

SW2: DN 10 = 27 mm, DN 15 = 30 mm, DN 20 = 37 mm

Values H1 and H2 are at the bearing surface thermostatic head or actuator.

Kvs = m³/h at a pressure drop of 1 bar and fully open valve.

Kv [xp] max. 2 K = m³/h at a pressure drop of 1 bar with thermostatic head.

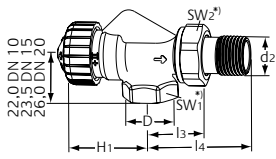
Axial

DN	D	d2	l3	l4	H1	Kv p-band max. 2 K	Kvs	EAN	Article No
10	Rp3/8	R3/8	24,5	50	34,5	0,025 - 0,670	0,86	4024052927517	3450-01.000
15	Rp1/2	R1/2	26	53	34,5	0,025 - 0,670	0,86	4024052927616	3450-02.000
20	Rp3/4	R3/4	30	63	34,5	0,025 - 0,670	0,86	4024052927715	3450-03.000

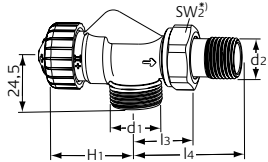
Axial

with external thread G3/4

DN	d1	d2	l3	l4	H1	Kv p-band max. 2 K	Kvs	EAN	Article No
15	G3/4	R1/2	26	53	34,5	0,025 - 0,670	0,86	4024052949519	3457-02.000

*) SW1: DN 10 = 22 mm, DN 15 = 27 mm, DN 20 = 32 mm
 SW2: DN 10 = 27 mm, DN 15 = 30 mm, DN 20 = 37 mm

Values H1 and H2 are at the bearing surface thermostatic head or actuator.

Kvs = m³/h at a pressure drop of 1 bar and fully open valve.

Kv [xp] max. 2 K = m³/h at a pressure drop of 1 bar with thermostatic head.

Accessories

Setting key

For V-exact II from 2012, Calypso exact, Calypso TRV-3 and Vekolux. Color grey.

EAN	Article No
4024052035823	3670-01.142

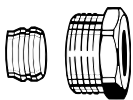
Compression fitting

for copper or precision steel pipe according to DIN EN 1057/10305-1/2. Internal thread connection Rp3/8 – Rp3/4. Metal-to-metal joint. Brass nickel-plated. Support sleeves should be used for a pipe wall thickness of 0.8 – 1 mm. Follow the specifications of the pipe manufacturer.

Ø Pipe	DN	EAN	Article No
12	10 (3/8")	4024052174614	2201-12.351
14	15 (1/2")	4024052174713	2201-14.351
15	15 (1/2")	4024052175017	2201-15.351
16	15 (1/2")	4024052175116	2201-16.351
18	20 (3/4")	4024052175215	2201-18.351

Support sleeve

for copper or precision steel pipe with a 1 mm wall thickness. Brass.

Ø Pipe	L	EAN	Article No
12	25,0	4024052127016	1300-12.170
15	26,0	4024052127917	1300-15.170
16	26,3	4024052128419	1300-16.170
18	26,8	4024052128815	1300-18.170

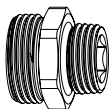
Double connection fitting

For clamping plastic, copper, precision steel or multi-layer pipes. Brass, nickel-plated.

L	EAN	Article No
G3/4 x R1/2 26	4024052308415	1321-12.083

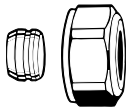

Compression fitting

for copper or precision steel pipe according to DIN EN 1057/10305-1/2. Connection external thread G3/4 according to DIN EN 16313 (Eurocone). Metal-to-metal joint. Brass nickel-plated. With a pipe wall thickness of 0.8-1 mm insert supporting sleeves. Heed pipe manufacturer's technical advice.

Ø Pipe	EAN	Article No
12	4024052214211	3831-12.351
14	4024052214310	3831-14.351
15	4024052214617	3831-15.351
16	4024052214914	3831-16.351
18	4024052215218	3831-18.351

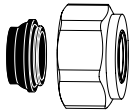

Compression fitting

for copper or precision steel pipe according to DIN EN 1057/10305-1/2 and stainless steel pipe. Connection external thread G3/4 according to DIN EN 16313 (Eurocone). Soft sealed, max. 95°C. Nickel-plated brass.

Ø Pipe	EAN	Article No
15	4024052515851	1313-15.351
18	4024052516056	1313-18.351

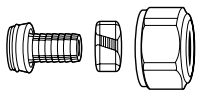

Compression fitting

for plastic pipe according to DIN 4726, ISO 10508. PE-X: DIN 16892/16893, EN ISO 15875; PB: DIN 16968/16969. Connection external thread G3/4 according to DIN EN 16313 (Eurocone). Nickel plated brass.

Ø Pipe	EAN	Article No
12x1,1	4024052136018	1315-12.351
14x2	4024052134618	1311-14.351
16x1,5	4024052136117	1315-16.351
16x2	4024052134816	1311-16.351
17x2	4024052134915	1311-17.351
18x2	4024052135110	1311-18.351
20x2	4024052135318	1311-20.351



Compression fitting

for Alu/PEX multi-layer pipe according to DIN 16836. Connection external thread G3/4 according to DIN EN 16313 (Eurocone). Nickel-plated brass.

Ø Pipe	EAN	Article No
16x2	4024052137312	1331-16.351
18x2	4024052137411	1331-18.351

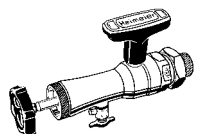

Fitting tool

complete with case, box spanner and replacement seals, for replacing thermostatic inserts without draining off the heating system (for DN 10 to DN 20).

	EAN	Article No
Fitting tool	4024052298914	9721-00.000



Replacement thermostatic insert

Calypso exact

	EAN	Article No
	4024052841417	3700-02.300



Replacement thermostatic insert for reversed flow direction

For thermostatic valve bodies with II marking, from 2012 and II+ marking, from 2015.

	EAN	Article No
	4024052951611	3700-24.300



The products, texts, photographs, graphics and diagrams in this document may be subject to alteration by IMI without prior notice or reasons being given. For the most up to date information about our products and specifications, please visit climatecontrol.imiplc.com.