

Climate
Control

IMI TA

STAD – NPT threads



Balancing valves
Size 1/2" - 2"

STAD – NPT threads

The STAD balancing valve delivers accurate hydronic performance in an impressive range of applications. Ideally suited for use on the secondary side in heating and cooling systems.

Key features

High accuracy for all settings

Ensure accurate balancing and flow reading.

Handwheel

Equipped with a digital read-out, the handwheel ensures accurate and straightforward balancing. Positive shut-off function for easy maintenance.

Self-sealing measuring points

For simple, accurate balancing.

AMETAL®

Dezincification resistant alloy that guarantees a longer valve lifetime and lowers the risk of leakage.



Technical description

Application:

Heating (not steam) and cooling systems.

Functions:

Balancing
Pre-setting
Measuring
Shut-off
Draining (depending on valve type)

Dimensions:

1/2" - 2"

Pressure class:

PN 25 (400 WWP)

Temperature:

Max. working temperature: 248°F
(intermittent 302°F)
Min. working temperature: -4°F

Media:

Water or neutral fluids, water-glycol mixtures (0-57%).

Material:

Valve body and bonnet: AMETAL®
Sealing (body/bonnet): EPDM O-ring
Valve plug: AMETAL®
Seat seal: EPDM O-ring
Spindle: AMETAL®
Slip washer: PTFE
Spindle seal: EPDM O-ring
Spring: Stainless steel
Handwheel: Polyamide and TPE

Measuring points: AMETAL®
Sealings: EPDM
Caps: Polyamide and TPE

Draining: AMETAL®
Sealing: EPDM
Gaskets: Fiber-based aramid

AMETAL® is the dezincification resistant alloy of IMI.

Marking:

Body: IMI, TA, PN 25/400 WWP, DN and inch size. Size 2" also CE.
Handwheel: TA, valve type and size.

Connection:

Internal thread NPT according to ANSI/ASME B1.20.1-1983.

Measuring points

Measuring points are self-sealed. Remove the cap and insert the probe through the seal.

Draining

Valves with draining for UNS 1 1/16" x 11.5 hose connection.

Sizing

When Δp and the design flow are known, use the formula to calculate the Cv value or use the diagram.

$$Cv = 1.52 \frac{q}{\sqrt{\Delta p}} \quad q \text{ in GPM, } \Delta p \text{ in ft WG}$$

$$Cv = \frac{q}{\sqrt{\Delta p}} \quad q \text{ in GPM, } \Delta p \text{ in psi}$$

Cv values

No of turns	1/2"	3/4"	1"	1 1/4"	1 1/2"	2"
0.5	0.157	0.616	0.693	1.38	2.19	3.03
1	0.261	0.903	1.19	2.42	3.93	4.74
1.5	0.401	1.41	2.46	3.88	5.48	7.82
2	0.714	2.25	4.21	6.03	7.23	13.2
2.5	1.08	3.13	6.08	8.98	10.6	18.3
3	1.69	4.29	7.69	11.4	14.8	24.9
3.5	2.39	5.21	9.01	13.8	18.7	31.2
4	2.96	6.23	9.93	16.4	22.3	37.3

NOTE: In softwares (HySelect, HyTools) and balancing instrument (TA-SCOPE) the STAD, PN 25/400 WWP version, is named STAD*.

Measuring accuracy

The zero position is calibrated and must not be changed.

Deviation of flow at different settings

The curve (Fig. 1) is valid for valves with normal pipe fittings (Fig. 2). Try also to avoid mounting taps and pumps, immediately before or after the valve.

The valve can be installed with the opposite flow direction. The specified flow details are also valid for this direction although tolerances can be greater (maximum 5% more).

Fig. 1

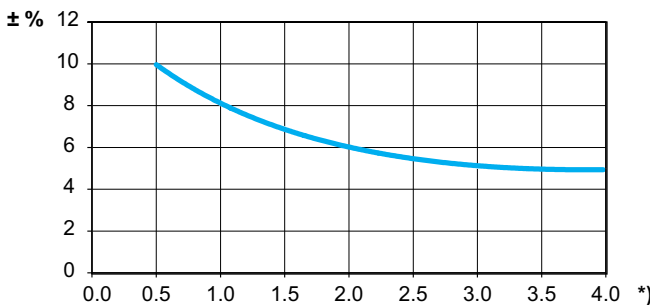
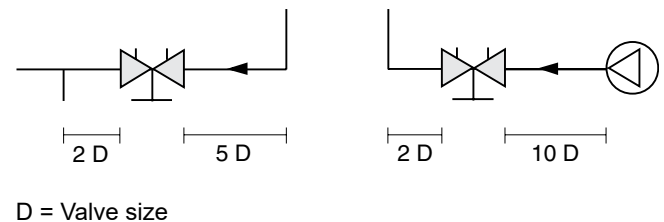

Fig. 2



*) Setting, No. of turns.

Correction factors

The flow calculations are valid for water (68°F). For other liquids with approximately the same viscosity as water (≤ 20 cSt = $3^\circ E=100S.U.$), it is only necessary to compensate for the specific density. However, at low temperatures, the viscosity increases and laminar flow may occur in the valves. This causes a flow deviation that increases with small valves, low settings and low differential pressures. Correction for this deviation can be made with the software HySelect or directly in our balancing instruments.

Installation

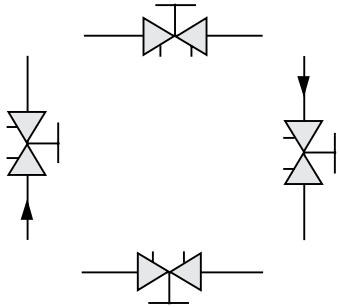

Setting

Setting of a valve for a particular pressure drop, e.g. corresponding to 2.3 turns on the graph, is carried out as follows:

1. Close the valve fully (Fig. 1).
2. Open the valve 2.3 turns (Fig. 2).
3. Using a 3 mm Allen key, turn the inner spindle clockwise until stop.
4. The valve is now set.

To check the setting: Close the valve, the indicator shows 0.0. Open it to the stop position. The indicator then shows the set value, in this case 2.3 (Fig. 2).

Diagrams showing the pressure drop for each valve size at different settings and flow rates are available to help determine the correct valve size and pre-setting (pressure drop).

Four turns corresponds to fully open valve (Fig. 3). Opening it further will not increase the capacity.

Fig. 1
Valve closed

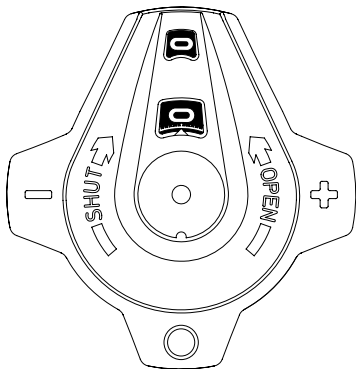

Fig. 2
The valve is set at 2.3

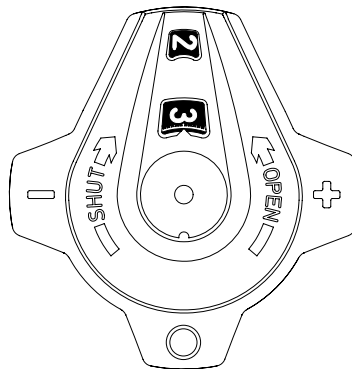

Fig. 3
Fully open valve

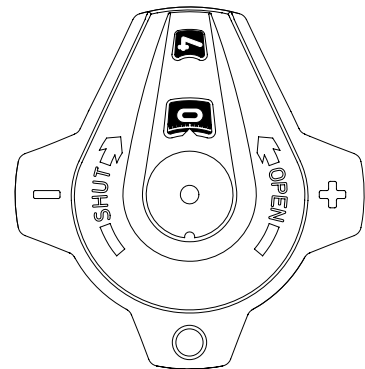

Diagram example

Wanted:

Presetting for size 1" at a desired flow rate of 7 gpm and a pressure drop of 3.2 ft.

Solution:

Draw a straight line joining 7 gpm and 3.2 ft. This gives $Cv=5.84$. Now draw a horizontal line from $Cv=5.84$. This intersects the bar for size 1" which gives 2.44 turns.

NOTE:

If the flow rate is out of the scale in the diagram, the reading can be made as follows:

Starting with the example above, we get 3.2 ft., $Cv=5.84$ and flow-rate 7 gpm.

At 3.2 ft. and $Cv=0.584$ we get the flow-rate 0.7 gpm, and at $Cv=58.4$, we get 70 gpm. That is, for a given pressure drop, it is possible to read 0.1 times or 10 times the flow and Cv -values.

Diagram

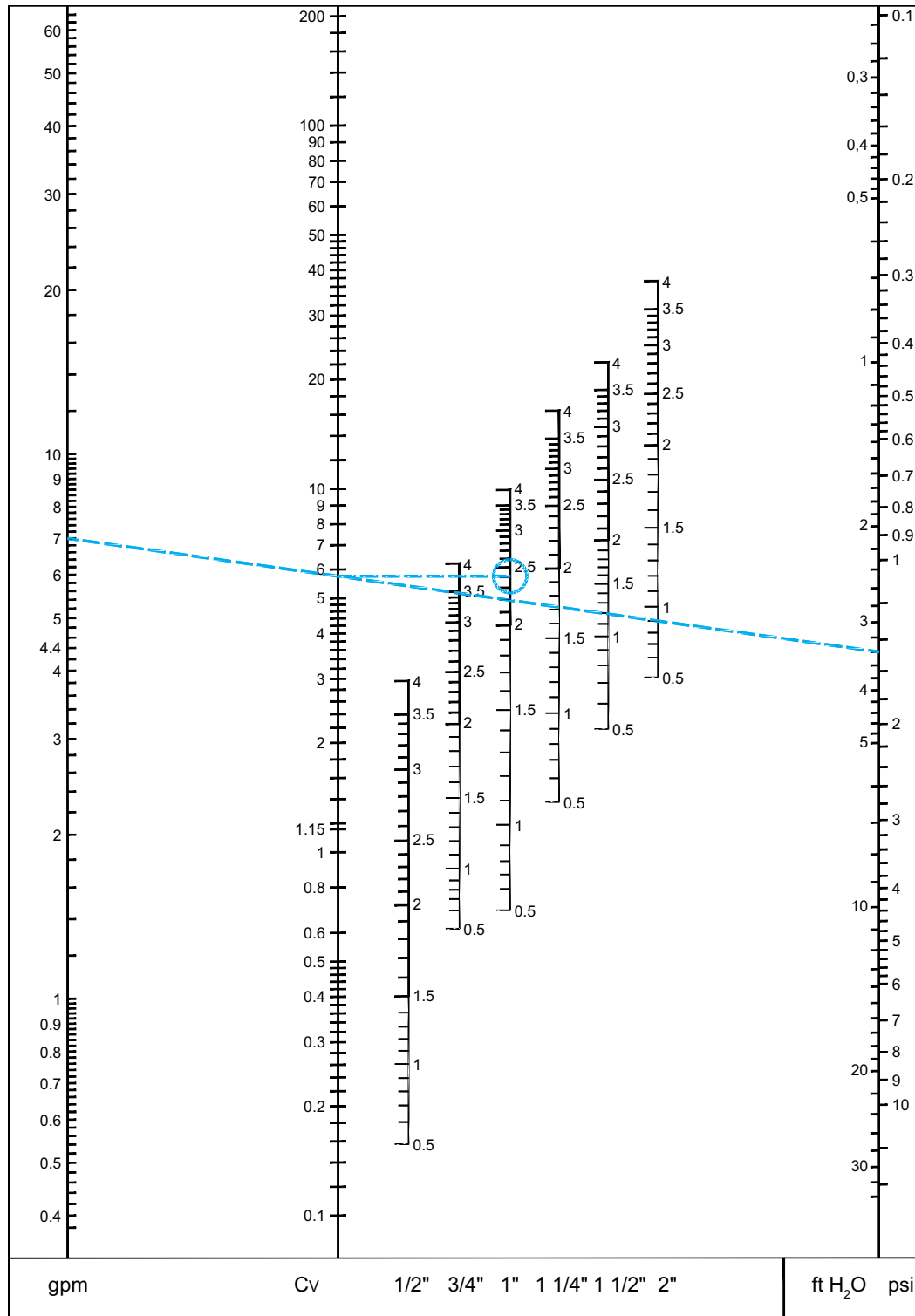

NOTE: In softwares (HySelect, HyTools) and balancing instrument (TA-SCOPE) the STAD, PN 25/400 WWP version, is named STAD*.

Articles

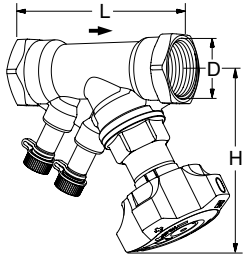

STAD – Without drain

Internal threads NPT.

Thread according to ANSI/ASME B1.20.1-1983.

Size	D	L [in]	H [in]	Cvs	Article No ** North America	Article No International
1/2"	1/2 NPT	3.31	3.94	2.96	52 867-515	52 851-515
3/4"	3/4 NPT	3.70	3.94	6.23	52 867-520	52 851-520
1"	1 NPT	4.13	4.13	9.93	52 867-525	52 851-525
1 1/4"	1 1/4 NPT	4.76	4.13	16.4	52 867-532	52 851-532
1 1/2"	1 1/2 NPT	4.96	4.72	22.3	52 867-540	52 851-540
2"	2 NPT	6.10	4.72	37.3	52 867-550	52 851-550

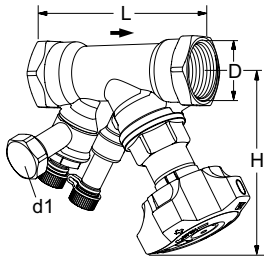

STAD – With drain

Internal threads NPT.

Thread according to ANSI/ASME B1.20.1-1983.

Size	D	L [in]	H [in]	Cvs	Article No ** North America	Article No International
d1 = UNS 1 1/16" x 11.5						
1/2"	1/2 NPT	3.31	3.94	2.96	52 867-715	52 851-715
3/4"	3/4 NPT	3.70	3.94	6.23	52 867-720	52 851-720
1"	1 NPT	4.13	4.13	9.93	52 867-725	52 851-725
1 1/4"	1 1/4 NPT	4.76	4.13	16.4	52 867-732	52 851-732
1 1/2"	1 1/2 NPT	4.96	4.72	22.3	52 867-740	52 851-740
2"	2 NPT	6.10	4.72	37.3	52 867-750	52 851-750

**) Distributed by Victaulic.

→ = Flow direction

Cvs = gpm at a pressure drop of 1 psi and fully open valve.

NOTE: In softwares (HySelect, HyTools) and balancing instrument (TA-SCOPE) the STAD, PN 25/400 WWP version, is named STAD*.

Accessories

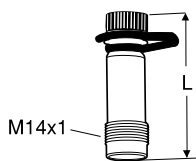

Measuring point

Max 248°F (intermittent 302°F)
AMETAL®/EPDM

L [in]	Article No
1.73	52 179-014
4.05	52 179-015

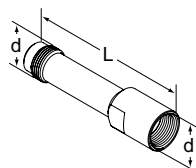

Extension for measuring point M14x1

Suitable when insulation is used.
AMETAL®

d	L [in]	Article No
M14x1	2.80	52 179-016

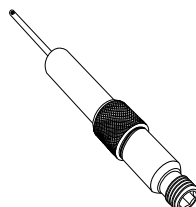

Measuring point, extension 2.36 in.
Can be installed without draining of the system.
AMETAL®/Stainless steel/EPDM

L [in]	Article No
2.36	52 179-006

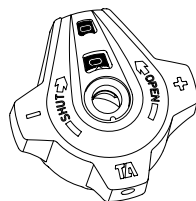

Handwheel

Complete

Article No ** North America	Article No International
52 167-820	52 186-007

**) Distributed by Victaulic.



Size plate, handwheel

Size	Article No
1/2N	310 308-01
3/4	310 308-02
1	310 308-03
1 1/4	310 308-04
1 1/2	310 308-05
2	310 308-06

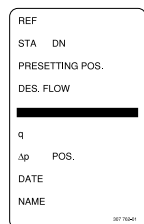

Identification tag

Article No
52 161-990



Allen key

[mm]		Article No
3	Pre-setting	52 187-103
5	Draining	52 187-105

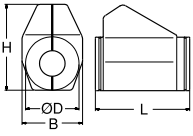

Insulation

For heating/cooling

Material: EPP

Fire class: B2 (DIN 4102)

Max working temperature: 248°F

(intermittent 284°F)

Min working temperature: 54°F, 18°F at sealed joints.

For size	L [in]	H [in]	D [in]	B [in]	Article No
3/8", 1/2", 3/4"	6.10	5.31	3.54	4.06	52 189-615
1"	6.89	5.59	3.70	4.06	52 189-625
1 1/4"	7.68	6.14	4.17	4.06	52 189-632
1 1/2"	8.43	6.65	4.25	4.45	52 189-640
2"	9.65	7.01	4.25	4.49	52 189-650