

**Climate
Control**

IMI Heimeier

Control valves for floor heating systems



Floor Heating Manifolds

Supply control valves with thermostatic insert
and lockshields

Control valves for floor heating systems

Supply control valves with thermostatic insert and lockshields specifically designed for the installation at heating manifolds.



Technical description

Application:

Floor heating systems

Function:

Control valve:
Control
Shut-off
Lockshield:
Presetting
Shut-off

Dimensions:

DN 15

Pressure class:

PN 10

Temperature:

Max. working temperature: 120°C
Min. working temperature: -10°C

Materials:

Control valve:
Valve body: corrosion resistant Gunmetal.
O-rings: EPDM rubber
Valve disc: EPDM rubber
Return spring: Stainless steel
Valve insert: Brass
The complete thermostatic insert can be replaced using the IMI Heimeier fitting tool without draining the system.
Spindle: Niro-steel spindle with double O-ring sealing. The outer O-ring can be replaced under pressure.

Lockshield:
Valve body: Corrosion-resistant gunmetal
Valve insert: Brass
Spindles: Brass
O-rings: EPDM

Marking:

THE, flow direction arrow

Pipe connection:

Connection Rp1/2 internal thread.
Connection R1/2 nipple, external thread.
Both connection sides with external thread G3/4 for compression fittings.
See also accessories.

Construction

Supply pipe control valve

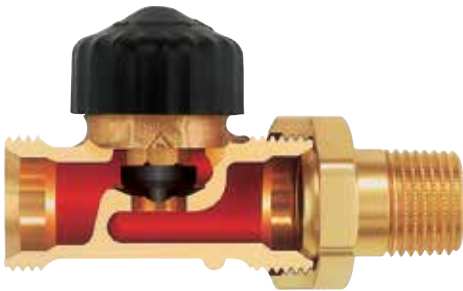

- Stainless spindle with double O-ring sealing
- The outer O-ring and thermostatic insert can be replaced during operation
- Can be manually adjusted with a handwheel cap
- Thermostatic operation with thermostatic head F or with thermal and motorized actuators with the corresponding room thermostats

Lockshield

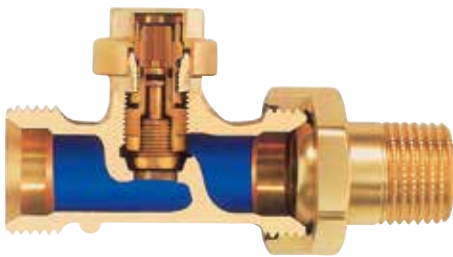

- Finest presetting through a doublecone construction, no stroke restriction
- Spindle sealing by O-rings
- No change to the presetting when opening or closing

Application

The supply pipe control valve is used

- Without a handwheel, for individual room temperature control with thermostatic head F, or with thermal and motorized actuators in connection with the appropriate room thermostats.
- With a handwheel, for manual operation. This model can be retrofitted to thermostatic individual room temperature control at low cost.

The hydraulic balancing of the heating circuits is carried out on the lockshields. Due to a special double cone construction, the presetting is not readjusted when the lockshield is opened or closed.

Sample application

Heating manifold

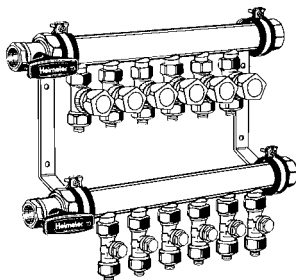

Notes

- To avoid damage and the formation of scale deposit in the hot-water heating system, the composition of the heat transfer medium should be in accordance with the VDI guideline 2035. For industrial and long-distance energy systems, see the applicable codes VdTÜV and 1466/AGFW FW 510. A heat transfer medium containing mineral oils, or any type of lubricant containing mineral oil can have extremely negative effects and usually lead to the disintegration of EPDM seals. When using nitrite-free frost and corrosion resistance solutions with an ethylene glycol base, pay close attention to the details outlined in the manufacturers' documentation, particularly concerning concentration and specific additives.
- Flush the system before changing thermostatic valves in heavy polluted existing systems.
- The thermostatic valve bodies can be used with all IMI Heimeier thermostatic heads and IMI Heimeier or IMI TA thermal actuators or motorized . The optimal tuning of the components guarantees maximum safety. When using actuators from other manufacturers, make sure that the pressure power is appropriate for thermostatic valve bodies with soft sealing valve discs.

Installation

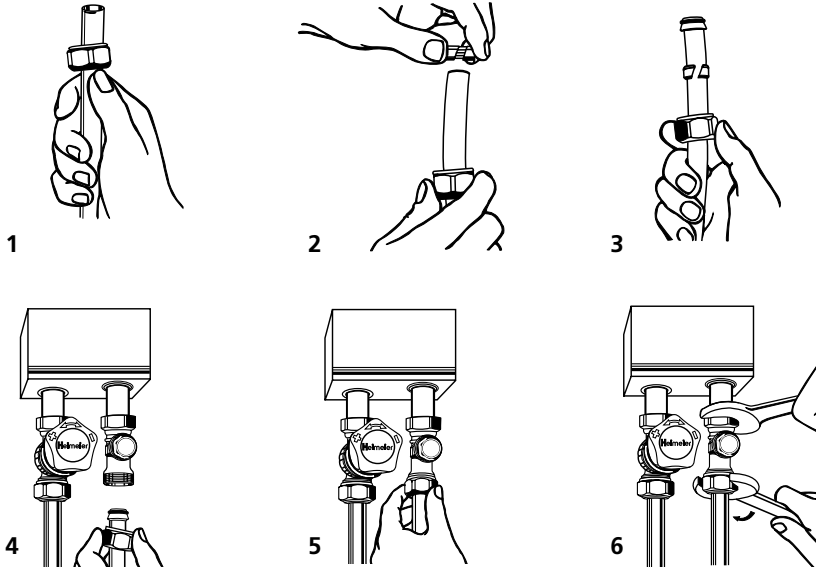

Plastic pipe

1. Cut off the plastic pipe at right angles and trim. Push the compression ring nut over the pipe.
2. Pull the compression ring over the pipe.
3. Position the hose nozzle and guide it while firmly holding the compression ring nut.
4. Push back the inserts and the plastic pipe.
5. Unscrew the compression ring nut by hand (push the plastic pipe until it stops).
6. Hold control valve with open-jawed wrench SW 27 and pull it tight with open-jawed wrench SW 30 (starting torque experimental value approx. 25 – 30 Nm).

Operation

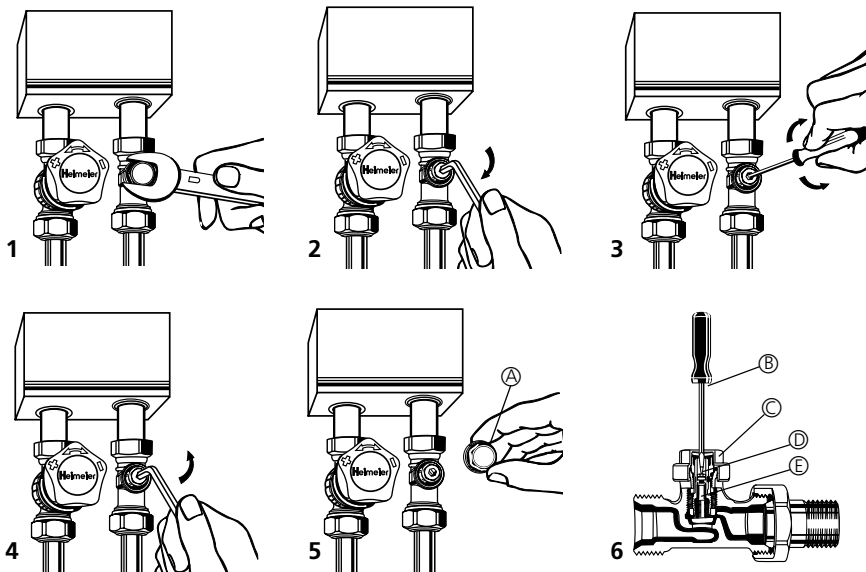

Lockshield – Presetting

1. Unscrew the closing cap with an open-jawed spanner SW 19.
2. Close the spindle by turning it to the right with a 5 mm hexagonal key until it stops.
3. Screw in the presetting cone with a 4 mm screw driver by turning it to the right until it stops (smallest setting value is 0). Set the required mass flow by turning the screw driver to the left. Take the setting value from the diagram.
4. Open the spindle by turning it to the left with a 5 mm hexagonal key until it stops.
5. Unscrew the closing cap and screw it tight with an open-jawed wrench SW 19.
6. There will be no changes to the presetting when the lockshield is opened or closed.

- A. Closing cap
- B. Screwdriver
- C. Closing cap
- D. Spindle
- E. Presetting cone

Technical data

Diagram supply pipe

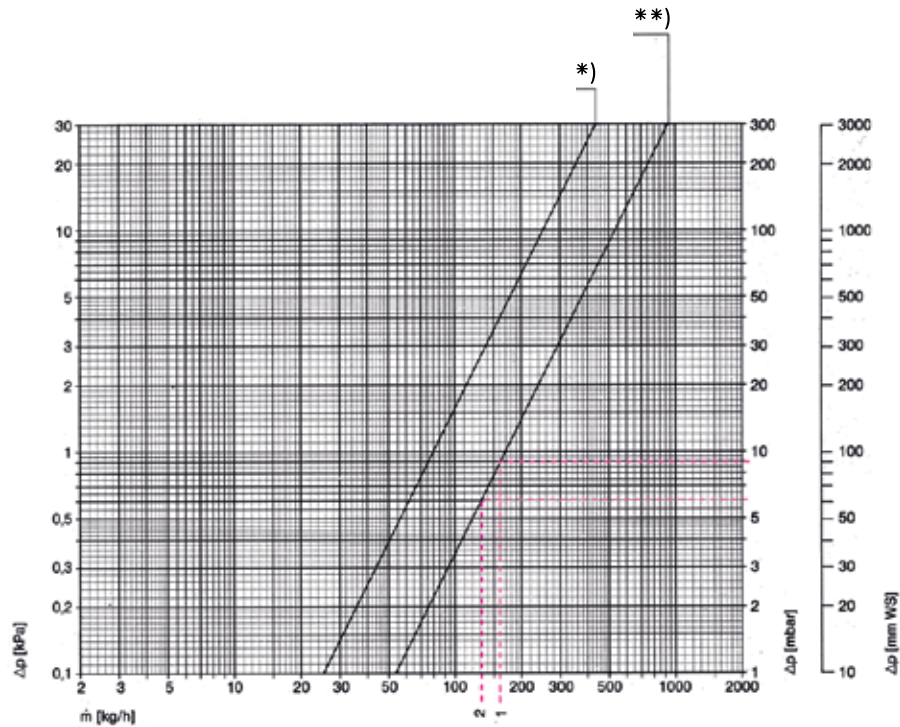

Thermostatic head with valve body		Kv-value P-band [K]					Kvs	Permitted differential pressure, when the valve is still closed Δp [bar]		
		1,0	1,5	2,0	2,5	3,0		Thermo.-head	EMO T/NC EMOtec/NC TA-TRI TA-Slider 160	EMO T/NO EMOtec/NO
DN 15	(1/2") Straight	0,38	0,59	0,79	0,95	1,10	1,70	1,0	2,7	3,5

*) Thermostatic head at 2 K P-band
 **) Handwheel (fully opened) / Actuator
 Kv/Kvs = m³/h at a pressure drop of 1 bar.

Sample calculation 1

Target:
 Heating circuit 1 total pressure loss

Given:
 Heat flow, incl. floor loss Q = 1490 W
 Temperature spread Δt = 8 K (44/36°C)
 Heating pipe \varnothing = 17 x 2 mm
 Pipe length incl. feed l = 90 m

Solution:
 Mass flow $m / (c \cdot \Delta t) = 1490 / (1,163 \cdot 8) = 160 \text{ kg/h}$
 Pressure loss in supply pipe control valve (with actuator) $\Delta p_v = 9 \text{ mbar}$
 Pressure loss in the lockshield (with open presetting) $\Delta p_{RV} = 15 \text{ mbar}$
 Pressure gradient in heating pipe R = 1.2 mbar/m
 Pressure loss in the heating pipe $\Delta p_R = R \cdot l = 1.2 \cdot 90 = 108 \text{ mbar}$
 Total pressure loss in the heating circuit 1 $\Delta p_{HK1} = \Delta p_v + \Delta p_{RV} + \Delta p_R = 132 \text{ mbar}$

$$Cv = \frac{Kv}{0,86}$$

$$Kv = Cv \cdot 0,86$$

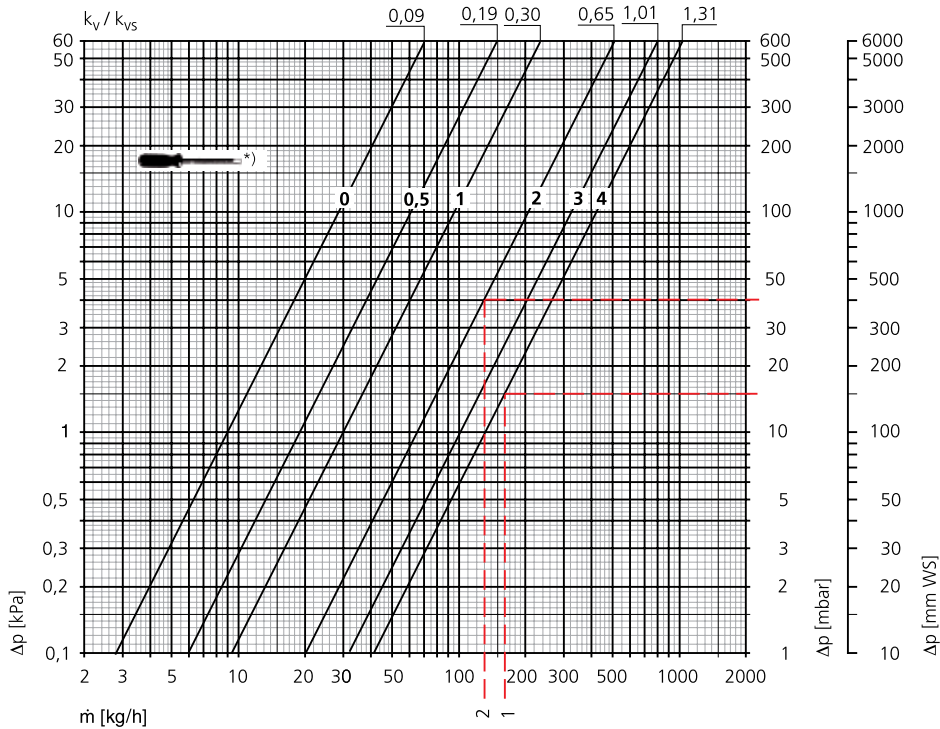
Diagram lockshield DN 15

*) Screwdriver rotations

$Kv/Kvs = m^3/h$ at a pressure drop of 1 bar.

Sample calculation 2

Target:

Presetting value for lockshield, heating circuit 2

Given:

Heat flow, incl. floor loss $Q = 1210 \text{ W}$

Temperature spread $\Delta t = 8 \text{ K}$ (44/36°C)

Heating pipe $\varnothing = 17 \times 2 \text{ mm}$

Pipe length incl. feed $l = 86 \text{ m}$

Pressure loss in the least efficient heating circuit $\Delta p_{HK1} = 132 \text{ mbar}$

Solution:

Mass flow $m = Q / (c \cdot \Delta t) = 1210 / (1,163 \cdot 8) = 130 \text{ kg/h}$

Pressure loss in the supply pipe valve (with handwheel) $\Delta p_V = 6 \text{ mbar}$

Pressure gradient in the heating pipe $R = 1.0 \text{ mbar/m}$

Pressure loss in the heating pipe $\Delta p_R = R \cdot l = 1.0 \cdot 86 = 86 \text{ mbar}$

Pressure loss in the lockshield $\Delta p_{RV} = \Delta p_{HK1} \cdot \Delta p_V \cdot \Delta p_R = 40 \text{ mbar}$

Presetting, from the diagram = 2.0 turns

$$Cv = \frac{Kv}{0,86}$$

$$Kv = Cv \cdot 0,86$$

Articles

Supply pipe control valve with thermostatic insert

Straight DN 15 (1/2")

Connection Rp 1/2 sleeve internal thread

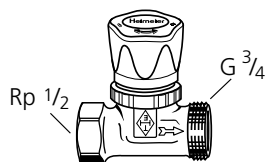

Model	Kv P-band	Kvs	EAN	Article No
	1 K / 2 K			
with handwheel	0,38 / 0,79	1,70	4024052132317	1302-02.000
without handwheel but with protection cap	0,38 / 0,79	1,70	4024052136414	1322-02.000

Connection R 1/2 nipple

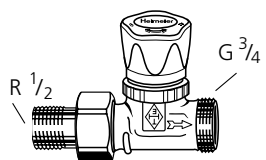

Model	Kv P-band	Kvs	EAN	Article No
	1 K / 2 K			
with handwheel	0,38 / 0,79	1,70	4024052133413	1304-02.000

Both connection sides with external thread G 3/4 for compression fittings

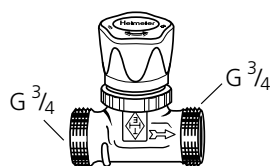

Model	Kv P-band	Kvs	EAN	Article No
	1 K / 2K			
with handwheel	0,38 / 0,79	1,70	4024052133918	1308-02.000
without handwheel but with protection cap	0,38 / 0,79	1,70	4024052136711	1328-02.000

Lockshield

Straight DN 15 (1/2")

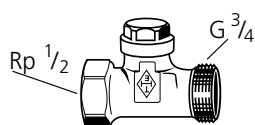

Model	Kvs	EAN	Article No
Connection Rp 1/2 sleeve internal thread	1,31	4024052119615	0402-02.000

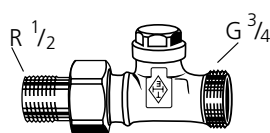

Model	Kvs	EAN	Article No
Connection R 1/2 nipple	1,31	4024052119813	0404-02.000

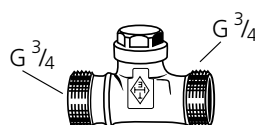

Model	Kvs	EAN	Article No
Both connection sides with external thread G 3/4 for compression fittings	1,31	4024052119912	0408-02.000

Kv/Kvs = m³/h at a pressure drop of 1 bar.

Accessories



Handwheel

for all IMI Heimeier thermostatic valve bodies. With direct connection, white.

EAN	Article No
4024052323494	1303-01.325

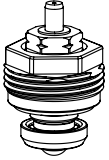

Thermostatic insert

Replacement insert. Stuffing box with black label.

EAN	Article No
4024052132614	1302-02.300

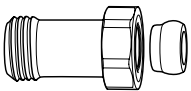

Length adjustment fitting

For clamping plastic, copper, precision steel or multi-layer pipes.

For valves with external thread connection G 3/4.

Brass nickel-plated.

	L	EAN	Article No
G3/4 x G3/4	25	4024052298310	9713-02.354
G3/4 x G3/4	50	4024052298419	9714-02.354

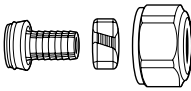

Compression fitting

for plastic pipe according to DIN 4726, ISO 10508.

PE-X: DIN 16892/16893, EN ISO 15875; PB: DIN 16968/16969.

Connection external thread G 3/4 according to DIN EN 16313 (Eurocone). Nickel plated brass.

Ø Pipe	EAN	Article No
12x1,1	4024052136018	1315-12.351
14x2	4024052134618	1311-14.351
16x1,5	4024052136117	1315-16.351
16x2	4024052134816	1311-16.351
17x2	4024052134915	1311-17.351
18x2	4024052135110	1311-18.351
20x2	4024052135318	1311-20.351

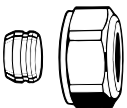

Compression fitting

for copper or precision steel pipe according to DIN EN 1057/10305-1/2.

Connection external thread G 3/4 according to DIN EN 16313 (Eurocone). Brass nickel-plated.

With a pipe wall thickness of 0.8-1 mm insert supporting sleeves. Heed pipe manufacturer's technical advice.

Ø Pipe	EAN	Article No
12	4024052214211	3831-12.351
14	4024052214310	3831-14.351
15	4024052214617	3831-15.351
16	4024052214914	3831-16.351
18	4024052215218	3831-18.351



Support sleeve

for copper or precision steel pipe with a 1 mm wall thickness.

Brass.

Ø Pipe	L	EAN	Article No
12	25,0	4024052127016	1300-12.170
15	26,0	4024052127917	1300-15.170
16	26,3	4024052128419	1300-16.170
18	26,8	4024052128815	1300-18.170

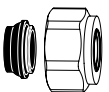

Compression fitting

for copper or precision steel pipe according to DIN EN 1057/10305-1/2 and stainless steel pipe.

Connection external thread G3/4 according to DIN EN 16313 (Eurocone). Soft sealed, max. 95°C.

Nickel-plated brass.

Ø Pipe	EAN	Article No
15	4024052515851	1313-15.351
18	4024052516056	1313-18.351



Compression fitting
for Alu/PEX multi-layer pipe according to DIN 16836.
Connection external thread G3/4 according to DIN EN 16313 (Eurocone).
Nickel-plated brass.

Ø Pipe	EAN	Article No
16x2	4024052137312	1331-16.351



Double connection fitting
For clamping plastic, copper, precision steel or multi-layer pipes.
Brass, nickel-plated.

L	EAN	Article No
G3/4 x R1/2 26	4024052308415	1321-12.083



Double nipple
Both sides for clamping plastic, copper, precision steel or multi-layer pipes.
Brass nickel-plated.

EAN	Article No
4024052136315	1321-03.081

Dimensions

Supply pipe control valves

1302-02.000

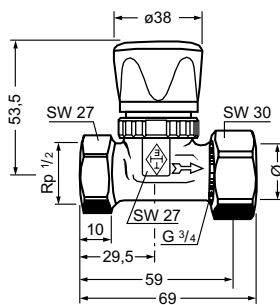

1304-02.000

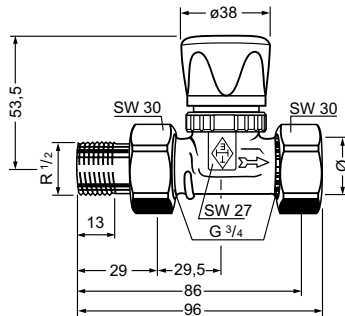

1308-02.000

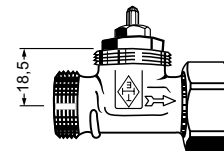
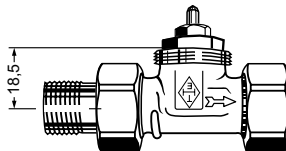
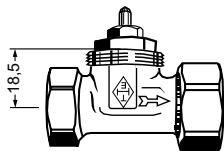
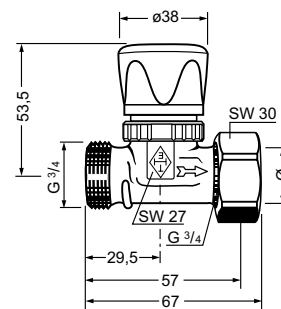

Lockshields

0402-02.000

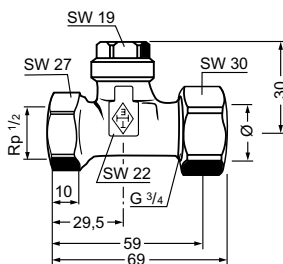

0404-02.000

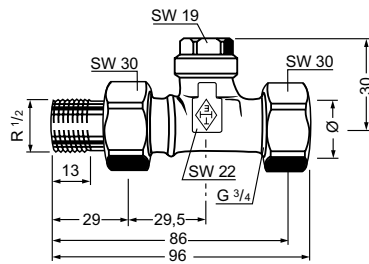

0408-02.000

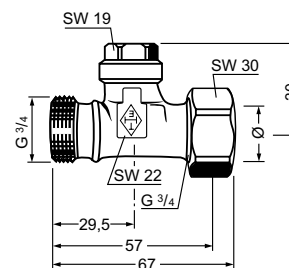

1 mm = 0,0394 inch



The products, texts, photographs, graphics and diagrams in this document may be subject to alteration by IMI without prior notice or reasons being given. For the most up to date information about our products and specifications, please visit climatecontrol.imiplc.com.