

Zeparo ZU



Automatic air vents and separators

Microbubble, dirt, combined

Zeparo ZU

Comprehensive range of products for venting and separation of micro bubbles, sludge, oxygen and magnetite in heating, solar and cooling water systems. The diversity of the applications as well as their modular construction is unique. The helistill separator makes these products incredibly efficient.

Key features

> Cleans and protects the installation

No risk of clogging. Reduces maintenance and associated costs over system lifetime.

> Magnet Accessory

Optimizes separation efficiency for sludge and even for finer magnetic particles. Can be ordered together with the Zeparo ZT or as a standalone accessory.

> Easy cleaning

Drain can be removed without pressure, allowing for easy cleaning of the separator.



Technical description

Application:

Heating, solar and chilled water systems.

Media:

Non-aggressive and non-toxic system media.
Addition of antifreeze agent up to 50%.

Pressure:

Max. admissible pressure, PS: 10 bar
Min. admissible pressure, PSmin: 0 bar

Temperature:

Max. admissible temperature, TS: 110 °C
Min. admissible temperature, TSmin: -10 °C

Zeparo ZUTS, ZUVS solar:

Max. admissible temperature, TS: 160 °C
Min. admissible temperature, TSmin: -10 °C

Material:

Vent, body, linkage: Brass
Helistill separator: Plastic PP - 30 % glass fibre
Gaskets: EPDM -10 – 110 °C | FPM (Viton) -10 – 160 °C
Float: Plastic -10 – 110 °C
Stainless steel -10 – 160 °C

Transportation and storage:

In frostless, dry places.

Diagrams

Approx. pressure loss (Δp) – Separator

Zeparo ZUV, ZUD, ZUM, ZUKM, ZUCM

DN 20-40

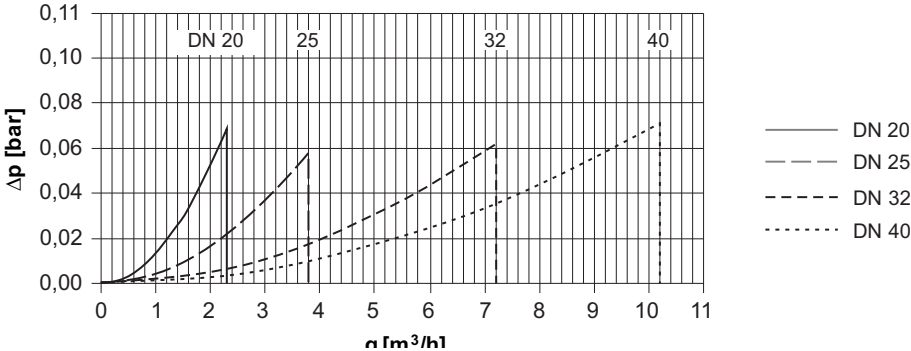

Zeparo DN 20-40 must operate within the limits $\leq q_N$.

Maximum system temperatures and static height above separator

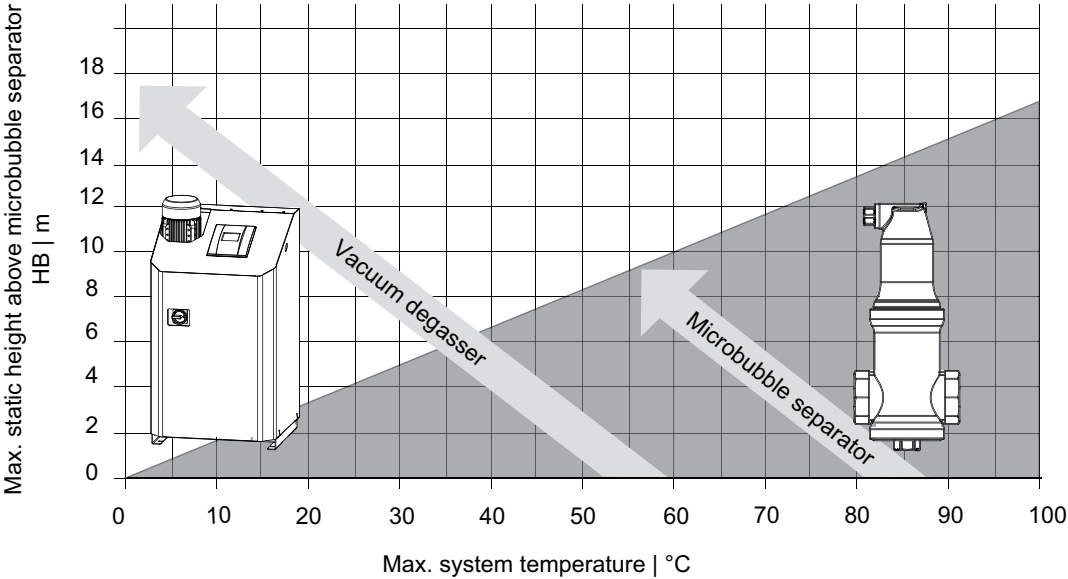

Separation principle

The Zeparo ZU family is based on a variety of principles that guarantee its high separation efficiency.

Helicoidal microbubble separator

- Low flow speed inside the separator allows large bubbles to rise quickly
- Large number of baffles in a spiral arrangement redirect bubbles upwards
- Smaller bubbles can rise in the central column with little turbulence
- With its many recesses and peaks, the helicoidal separator has an extensive overall surface area, capturing microbubbles in an optimal way

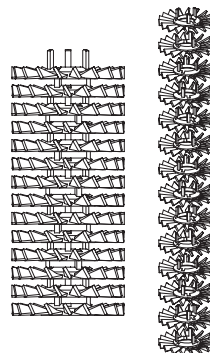

Air and dirt separation

- Integration with dry magnet separator is possible.
- The implementation of the principle takes place with the helistill separator in a separation chamber.
- Best separation performance for micro bubbles and sludge particles.
- More efficient separation of magnetic fine sludges when combined with dry magnetic rod in pocket tube.
- No additional energy input due to minimal pressure losses and always free-flow path.



Air Vents

- Safe, dry discharge of separated gases.
- Stable float handling in a large, flow-balanced chamber. Dirt and water are kept away from the precision valve, also at high pressures.
- Emergency screw plug with signal function just in case, in the unlikely event that it starts to leak.
- No damaging leakage, no calcium deposit.
- No operation and replacement costs through leaking automatic air vent.
- Reliable, high capacity even at high pressures.

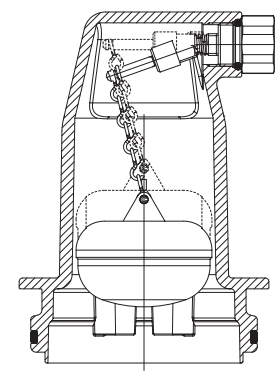

Application examples

The following circuit drawings illustrate preferred solutions. Alterations are possible under the condition that applicable HB limit values are maintained.

Heating system

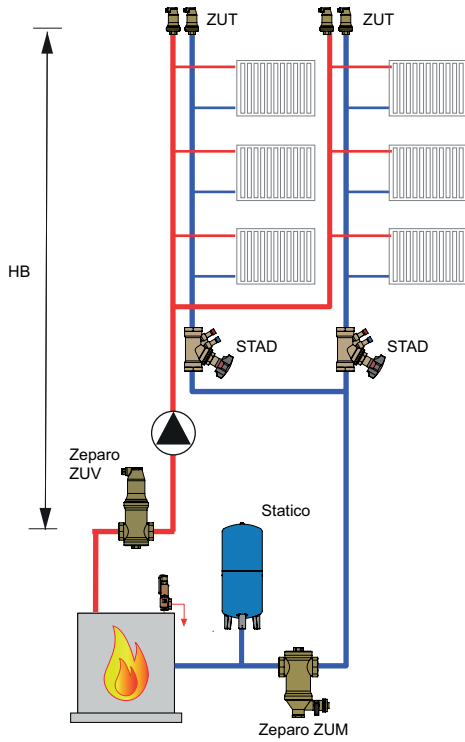

Wall-mounted gas boiler

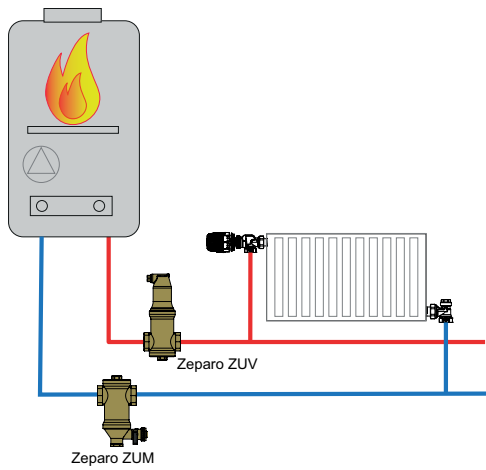

Heat pump system

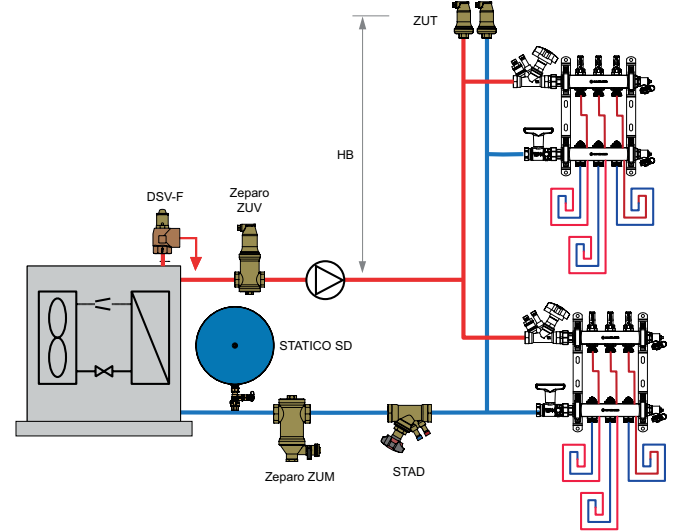

Solar heating

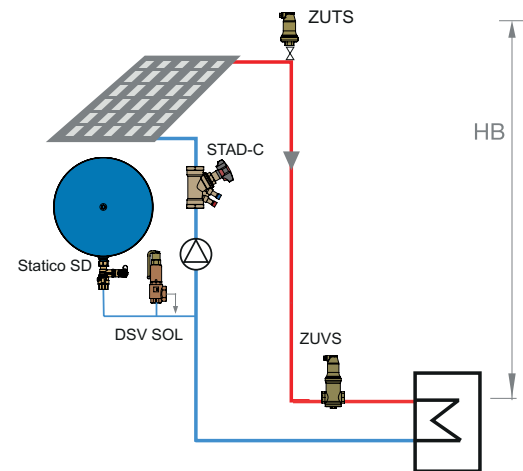

Cooling system

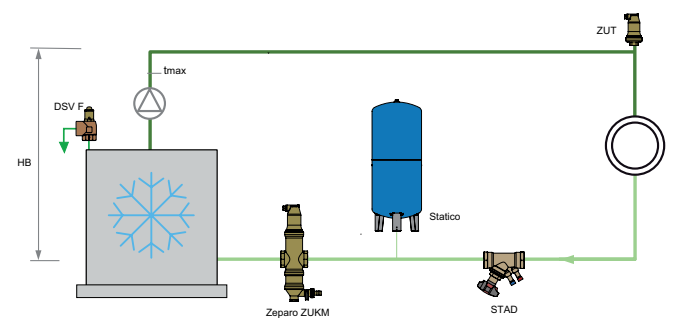

Low-loss headers

Primary volumetric flow q_1 . Secondary volumetric flow q_2 .

Case A:

Primary flow $q_1 >$ Secondary flow q_2

To be used where secondary flow q_2 mixes with the return flow at customer circuits, thereby getting reduced to such levels that the effectiveness of generators is no longer ensured. Not suitable for condensating boilers.

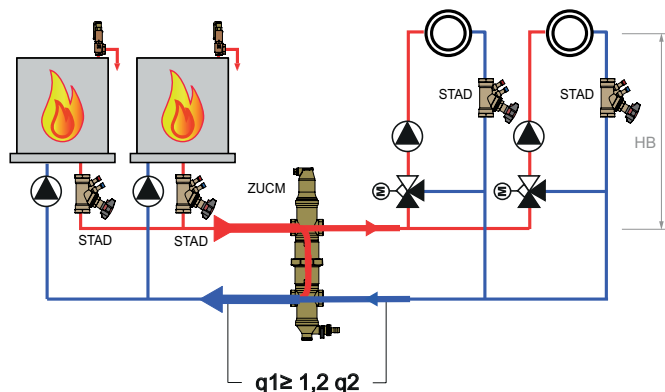

ZUCM	q_1 [m ³ /h]
20	≤ 1,25
25	≤ 2
32	≤ 3,7
40	≤ 5

Case B:

Primary flow $q_1 <$ Secondary flow q_2

Used primarily with condensating boilers in combination with underfloor heating systems. Secondary flow q_2 of the underfloor heating is higher than the flow q_1 produced by the condensating boiler. Water heaters should be connected on the boiler side before the header.

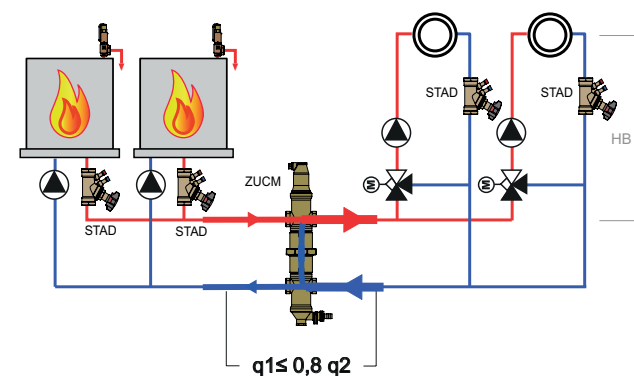

ZUCM	q_1 [m ³ /h]
20	≤ 1,25
25	≤ 2
32	≤ 3,7
40	≤ 5

Zeparo ZUT / ZUP – Automatic air vent, versions Top and Purge

Suitable for initial venting at high levels when the system is being filled. Also for the operational venting of radiators in small systems at higher levels. To be installed in the flow and return pipes at the end of risers, at relatively high points in the system.

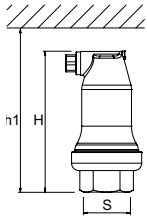

Zeparo ZUT

Female thread. Vertical installation.

Type	H	h1	m [kg]	S	dpu [bar]	EAN	Article No
ZUT 15	124	149	0,6	Rp1/2	10	7640148632454	789 0515
ZUT 20	124	149	0,7	Rp3/4	10	7640148632461	789 0520
ZUT 25	124	149	0,7	Rp1	10	7640148632478	789 0525

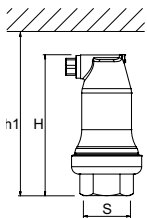

Zeparo ZUTS solar

Female thread. Vertical installation.

Type	H	h1	m [kg]	S	dpu [bar]	EAN	Article No
ZUTS 15	124	149	0,6	Rp1/2	10	7640148632492	789 1615

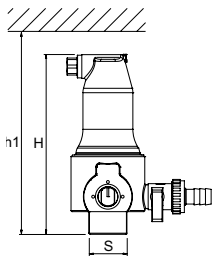

Zeparo ZUTX eXtra-lockable

Male thread. Vertical installation.

Type	H	h1	m [kg]	S	dpu [bar]	EAN	Article No
ZUTX 25	159	184	1,3	R1	10	7640148632485	789 1325

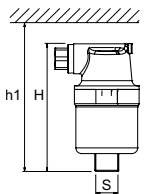

Zeparo ZUP

Male thread. Vertical installation.

Type	H	h1	m [kg]	S	dpu [bar]	EAN	Article No
ZUP 10	90	110	0,4	R3/8	6	7640148632508	789 1510

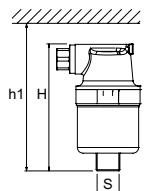

Zeparo ZUPN

ZUPN 10 Male thread. ZUPN 15 Female thread. Vertical installation.

Nickel plated.

Type	H	h1	m [kg]	S	dpu [bar]	EAN	Article No
ZUPN 10	90	110	0,4	R3/8	6	7640161644359	789 1511
ZUPN 15	93	110	0,4	Rp1/2	6	7640161644366	789 1516

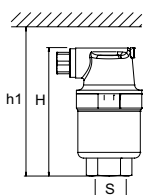

dpu = Working pressure range

Zeparo ZUV – Microbubble separator, version Vent

Intended for operational venting. Effectiveness is limited by static height (HB) above the separator (see table below). To be installed in the main flow pipe near the heat generator, or, in chilled water systems, in the warmer return pipe close to the chiller.

HB = static height required for microbubble separation at maximum system temperature upstream of the separator.

tmax	°C	90	80	70	60	50	40	30	20	10
HB	mWs	15,0	13,4	11,7	10,0	8,4	6,7	5,0	3,3	1,7

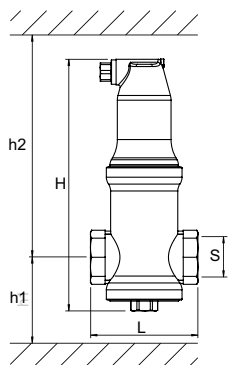

Zeparo ZUV

Female thread. Horizontal installation.

Type	H	h1	h2	L	m	S	qN	qN _{max}	EAN	Article No
					[kg]		[m³/h]	[m³/h]		
ZUV 20	204	73	176	88	1,1	G3/4	1,3	2,3	7640148632522	789 1120
ZUV 25	207	64	188	88	1,2	G1	2,1	3,8	7640148632546	789 1125
ZUV 32	239	81	203	88	1,4	G1 1/4	3,7	7,2	7640148632553	789 1132
ZUV 40	273	83	235	88	1,5	G1 1/2	5	10,2	7640148632560	789 1140

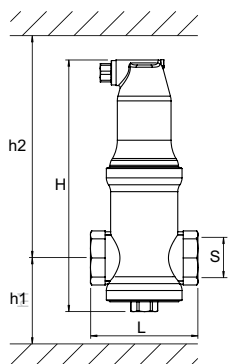

Zeparo ZUVS solar

Female thread. Horizontal installation.

Type	H	h1	h2	L	m	S	qN	qN _{max}	EAN	Article No
					[kg]		[m³/h]	[m³/h]		
ZUVS 20	204	73	176	88	1,1	G3/4	1,3	2,3	7640148632607	789 1720
ZUVS 25	207	64	188	88	1,2	G1	2,1	3,8	7640148632621	789 1725
ZUVS 32	239	81	203	88	1,4	G1 1/4	3,7	7,2	7640148632638	789 1732
ZUVS 40	273	83	235	88	1,5	G1 1/2	5	10,2	7640148632645	789 1740

qN = Nominal flow/flow rate

qN_{max} = Maximum flow

Zeparo ZUD / ZUM – Separator for sludge particles, versions Dirt and Magnetic

Suitable for in-service de-sludging. Preferably installed upstream of system components – heat generators, metering/heat measuring devices, pumps – that require protection. The ZU...M version that features a magnetic insert is particularly effective.

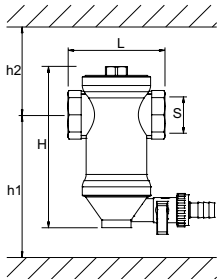

Zeparo ZUD

Female thread. Horizontal installation.

Type	H	h1	h2	L	m [kg]	S	qN [m ³ /h]	qN _{max} [m ³ /h]	EAN	Article No
ZUD 20	141	128	78	88	0,9	G3/4	1,3	2,3	7640148632683	789 2120
ZUD 25	144	140	69	88	1,0	G1	2,1	3,8	7640148632706	789 2125
ZUD 32	176	155	86	88	1,2	G1 1/4	3,7	7,2	7640148632713	789 2132
ZUD 40	210	187	88	88	1,4	G1 1/2	5,0	10,2	7640148632720	789 2140

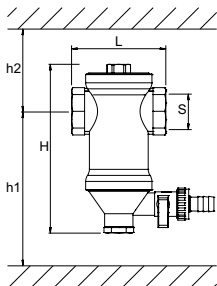

Zeparo ZUM with magnetic action

Female thread. Horizontal installation.

Type	H	h1	h2	L	m [kg]	S	qN [m ³ /h]	qN _{max} [m ³ /h]	EAN	Article No
ZUM 20	155	202	78	88	1,2	G3/4	1,3	2,3	7640148632768	789 3120
ZUM 25	158	214	70	88	1,3	G1	2,1	3,8	7640148632782	789 3125
ZUM 32	190	229	86	88	1,5	G1 1/4	3,7	7,2	7640148632799	789 3132
ZUM 40	224	261	86	88	1,6	G1 1/2	5	10,2	7640148632805	789 3140

qN = Nominal flow/flow rate

qN_{max} = Maximum flow

Zeparo ZUKM – Separator for microbubbles and sludge, version Kombi

Combined operational venting and de-sludging. In chilled water systems, installation is recommended upstream of the chiller. This way, not only is the generator protected from sludge accumulation, but the relatively high temperatures are optimal for bubble separation. Rooftop heating installations also provide outstanding conditions for combined initial/operational venting and de-sludging. Microbubble separation is only guaranteed if HB values are not exceeded.

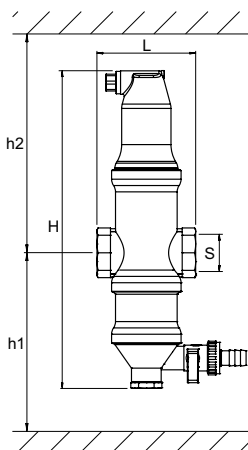

Zeparo ZUKM

Dry magnetic rod in pocket to increase the magnetite capture.

Female thread. Horizontal installation.

Type	H	h1	h2	L	m [kg]	S	qN [m ³ /h]	qN _{max} [m ³ /h]	EAN	Article No
ZUKM 20	281	230	176	88	1,6	G3/4	1,3	2,3	7640148632898	789 4220
ZUKM 25	284	221	186	88	1,7	G1	2,1	3,8	7640148632911	789 4225
ZUKM 32	316	238	203	88	1,9	G1 1/4	3,7	7,2	7640148632928	789 4232
ZUKM 40	350	240	235	88	2,0	G1 1/2	5	10,2	7640148632935	789 4240

qN = Nominal flow/flow rate

qN_{max} = Maximum flow

Zeparo ZUCM – Low-loss header with separator for microbubbles and sludge particles, version Collect

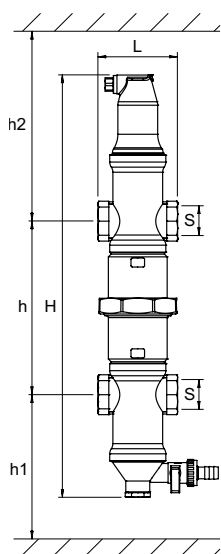

Suitable for the hydraulic decoupling of generators and consumer circuits, in combination with operational venting and de-sludging. To be installed between generator and consumer circuits. Integrated microbubble separation is only guaranteed if HB values are not exceeded. For optimal operation, the volumetric flow conditions as indicated below must be set between q_1 and q_2 (see case examples on page 5).

Zeparo ZUCM with magnetic action

Dry magnetic rod in pocket to increase the magnetite capture.
Female thread. Horizontal installation.

Type	H	h	h1	h2	L	m [kg]	S	qN [m ³ /h]	qN _{max} [m ³ /h]	EAN	Article No
ZUCM 20	464	211	202	176	88	2,9	G3/4	1,3	2,3	7640148632997	789 5220
ZUCM 25	470	193	214	186	88	3,2	G1	2,1	3,8	7640148633017	789 5225
ZUCM 32	534	227	229	203	88	3,7	G1 1/4	3,7	7,2	7640148633024	789 5232
ZUCM 40	602	231	261	235	88	4,0	G1 1/2	5	10,2	7640148633031	789 5240

qN = Nominal flow/flow rate

qN_{max} = Maximum flow

Accessories for separators

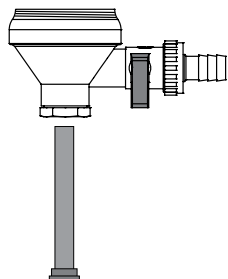

Zeparo ZU – Magnet upgrade kit

High-performance magnet upgrade for ZUK, ZUC or ZUD separators without magnet. Kit includes lower separator section, drain valve and magnetic pocket rod. Body of the old separator can remain in the system.

Type	m [kg]	EAN	Article No
ZUM bottom part	0,3	5902276808180	30401060800

Zeparo ZHU – Thermal insulation for Zeparo ZUC, ZUD, ZUK, ZUT, ZUV

Heating water systems.

Expanded polypropylene (EPP), anthracite.

Insulation value approx. 0.035 W/mk.

Fire rating B2 to DIN 4102.

Max. admissible temperature: 110 °C.

Min. admissible temperature: 10 °C.

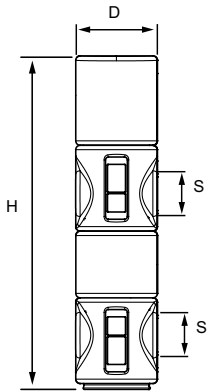
ZHU-ZUC/ZUCM

D	H	SD	m [kg]	S [DN]	EAN	Article No
112	447	24	0,142	25	7640148639040	787 1525
112	511	24	0,146	32	7640148639088	787 1532
112	579	24	0,165	40	7640148639125	787 1540

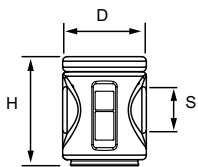
ZHU-ZUD/ZUM

D	H	SD	m [kg]	S [DN]	EAN	Article No
112	144	24	0,044	20-22	7640148638982	787 1422
112	147	24	0,053	25	7640148639033	787 1425
112	179	24	0,055	32	7640148639071	787 1432
112	239	24	0,064	40	7640148639118	787 1440

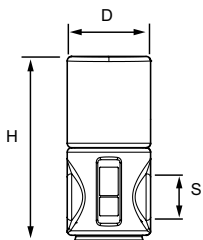
ZHU-ZUKM

D	H	SD	m [kg]	S [DN]	EAN	Article No
112	244	24	0,070	20-22	7640148638975	787 1322
112	247	24	0,079	25	7640148639019	787 1325
112	279	24	0,080	32	7640148639064	787 1332
112	313	24	0,090	40	7640148639101	787 1340

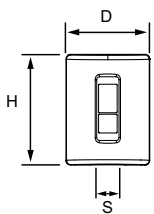
ZHU-ZUT

D	H	SD	m [kg]	S [DN]	EAN	Article No
112	147	24	0,058	15-25	7640148639026	787 1125

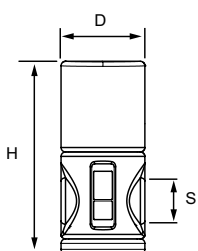
ZHU-ZUV

D	H	SD	m [kg]	S [DN]	EAN	Article No
112	258	24	0,079	20-22	7640148638968	787 1222
112	261	24	0,088	25	7640148639002	787 1225
112	293	24	0,090	32	7640148639057	787 1232
112	327	24	0,100	40	7640148639095	787 1240

Additional information

 For a list of abbreviations and terminology, refer to the document *Planning and Calculation*.

