

More savings. **Better comfort.**

# Renovation of Residential HVAC Systems

**INSTALLER EDITION**





# [ Index ]

- Why renovate? ..... 3
- Energy Efficiency Roadmap ..... 4
- Key aspects to consider before renovating ..... 6
- Heat Source..... 8
- Pressurisation ..... 22
- Water Quality ..... 32
- Hydronic Balancing..... 40
- Thermostatic & Room Control ..... 48
- Our products in action ..... 63
- Our expertise applied ..... 72

# [ Why renovate? ]

With the EU's goal of achieving **climate neutrality by 2050**, the renovation of existing housing stock across Europe becomes crucial to enhance **sustainability and energy efficiency**, and, as a HVAC professional, you play a critical role in helping the EU achieve this objective.

The **heating, ventilation, and air conditioning ('HVAC') system** accounts for 50% of a building's energy consumption, taking center stage in residential renovation projects. Fortunately, **significant improvements can be made without the need for drastic measures**. In this eBook, we cover the key areas of consideration of HVAC systems, how to address common questions and provide practical guidance for implementing changes that improve **energy efficiency** in homes.

**IMI Hydronic Engineering** is here to support you as a trusted partner in overcoming the challenges associated with residential building renovations. We are a leading hydronic expert with over **300 years of combined experience from our reputable brands**:

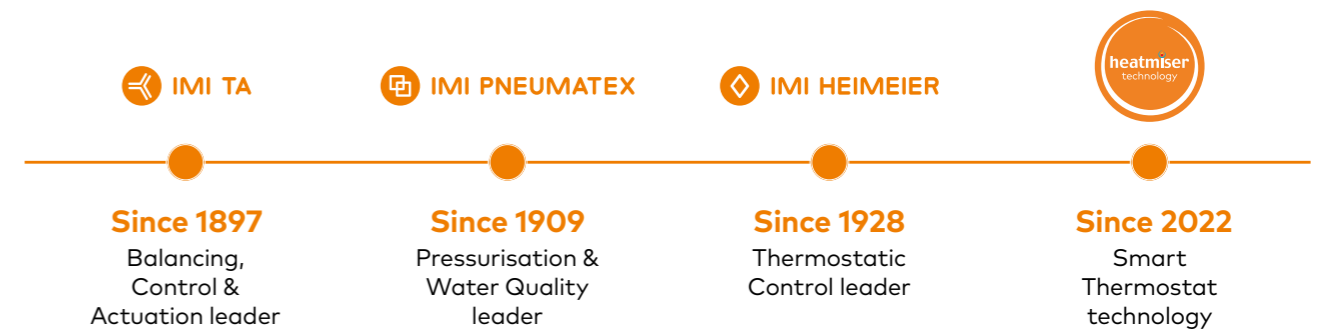

# Energy Efficiency Roadmap

Buildings account for **40% of the global energy consumption** and are a significant contributor to CO<sub>2</sub> emissions. As concerns about climate change continue to grow and energy costs rise, it is critical to find versatile and effective solutions **that enhance the energy efficiency of buildings** and provide us the opportunity to create a **better world** for all.

## Benefits of renovating your residential property



Reduce emissions and associated energy costs



Enhance tenants' living environment



Increase the resale value of your property

## Carbon Neutrality by 2050

The **European Commission** has set out a **long-term strategy to reach carbon-neutrality**. Below we have compiled some of the key directives and targets that will directly impact your job and customers.

**75%**  
of the building stock in Europe is energy-inefficient by today's standards

**40%**  
of the building stock in Europe was constructed before energy performance requirements were introduced

**2050**

- **Climate Neutrality: Reduce emissions by 80-95%** compared to 1990 levels  
(Directive 2010/31/EU)

**2030**

- At least **55% reduction in greenhouse gas emissions** from 1990 levels  
("Fit for 55" package, 2021)
- **Double the annual renovation rate** = **35 million** building units renovated by 2030  
(The Renovation Wave Strategy, 2020)

**2023**

- **In March 2023, the European Parliament passed a new directive\* for the Climate and Resilience Act**, mandating property owners to renovate energy-intensive homes or face penalties when selling or prohibiting them from renting them out.  
(\*P9\_TA(2023)0068).

**2021**

- **The European Commission proposed a revision of the Energy Performance of Buildings Directive (EPBD)** Promotes **energy efficiency in buildings** within the European Union.  
(2021/0426 (COD))  
The first version of the EPBD was published in 2002 (Directive 2002/91/EC).

# Key aspects to consider before renovating

Outside temperature, building size, occupancy, and insulation are key variables that can impact your HVAC system's energy consumption. However, they are not the only factors to consider. The symbiotic operation of your heating & cooling equipment plays crucial role in determining energy consumption and potential savings.

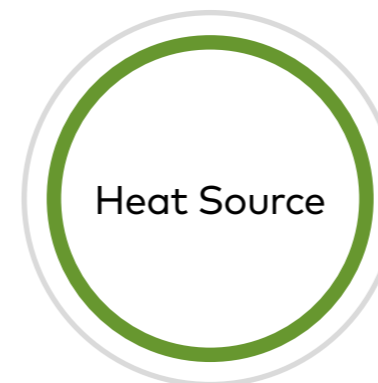
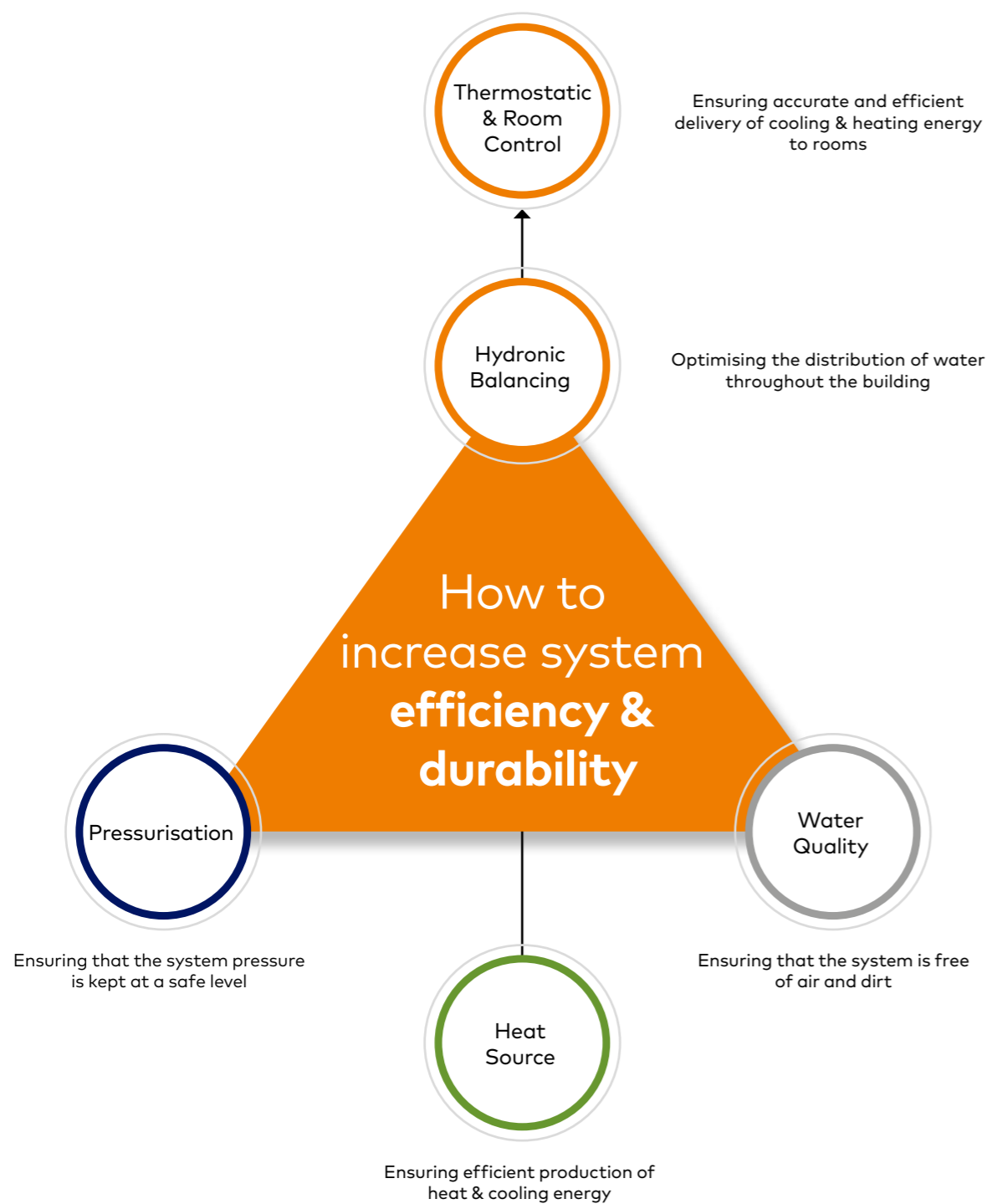

**Heat pumps** are increasingly adopted thanks to their **energy efficiency and zero carbon impact**, as they utilise existing heat from the environment. They are available in different types and categorised based on heat collection and transfer locations: Air/Air, Air/Water, or Ground/Water. **More on page 8.**



**Maintaining proper pressurisation is essential in HVAC systems.** Temperature fluctuations cause water to expand or contract, resulting in pressure changes that strain system components. Excessive pressure can lead to ruptures or failures, while reduced pressure causes air intake and corrosion. **More on page 24.**



Ensuring proper water quality is crucial for **optimal HVAC system performance and its components' longevity.** Removing air and dirt brings significant advantages such as reduced energy consumption, extended service life, and quiet operation. **More on page 34.**



**Hydronic balancing** is essential to ensure proper water flow throughout the system, allowing each terminal unit to receive its designated flow regardless of operating conditions. It optimises water distribution in buildings, providing **maximum comfort while minimising energy costs.** **More on page 42.**



**High-quality thermostatic & room control is paramount** for you, as an installer, to deliver energy-efficient heating and cooling systems that provide the desired indoor comfort levels for homeowners. **More on page 50.**

# More on Heat Pumps

## How it works

A heat pump consists of essential components, including two heat exchangers (evaporator and condenser), a compressor, and a pressure relief valve. These components work together with a circulating refrigerant inside the heat pump.

The evaporator, located on the cold side of the heat pump, facilitates the evaporation of the refrigerant, using the heat from the surrounding environment such as air, geothermal closed glycol circuits, or water sources. On the hot side of the heat pump (in-house installation), the refrigerant condenses from gas to liquid, releasing heat to the surroundings.

The compressor plays a crucial role in maintaining different temperatures for evaporation and condensation on the hot and cold sides. By changing the pressure of the refrigerant, the boiling points (evaporation and condensation temperatures) are adjusted. This allows the fluid to evaporate at a lower temperature on the cold side and condense at a higher temperature on the hot side, effectively transferring heat from a colder source to a warmer location.



### Good to know

EU Governments are actively working to phase out fossil fuel heating systems from households, aiming for the transition to be complete by 2035, with a deadline set for 2040 at the latest. As an alternative, they are offering subsidies to homeowners for installing sustainable energy generators (such as heat pumps), improving insulation, and connecting to district heating.

**In France, homeowners can receive €5,000 in government support when replacing an oil/gas boiler with a heat pump.**

Source: <https://france-renov.gouv.fr/sites/default/files/2023-01/Guide-des-aides-financieres-2023.pdf>

## Types of heat pumps

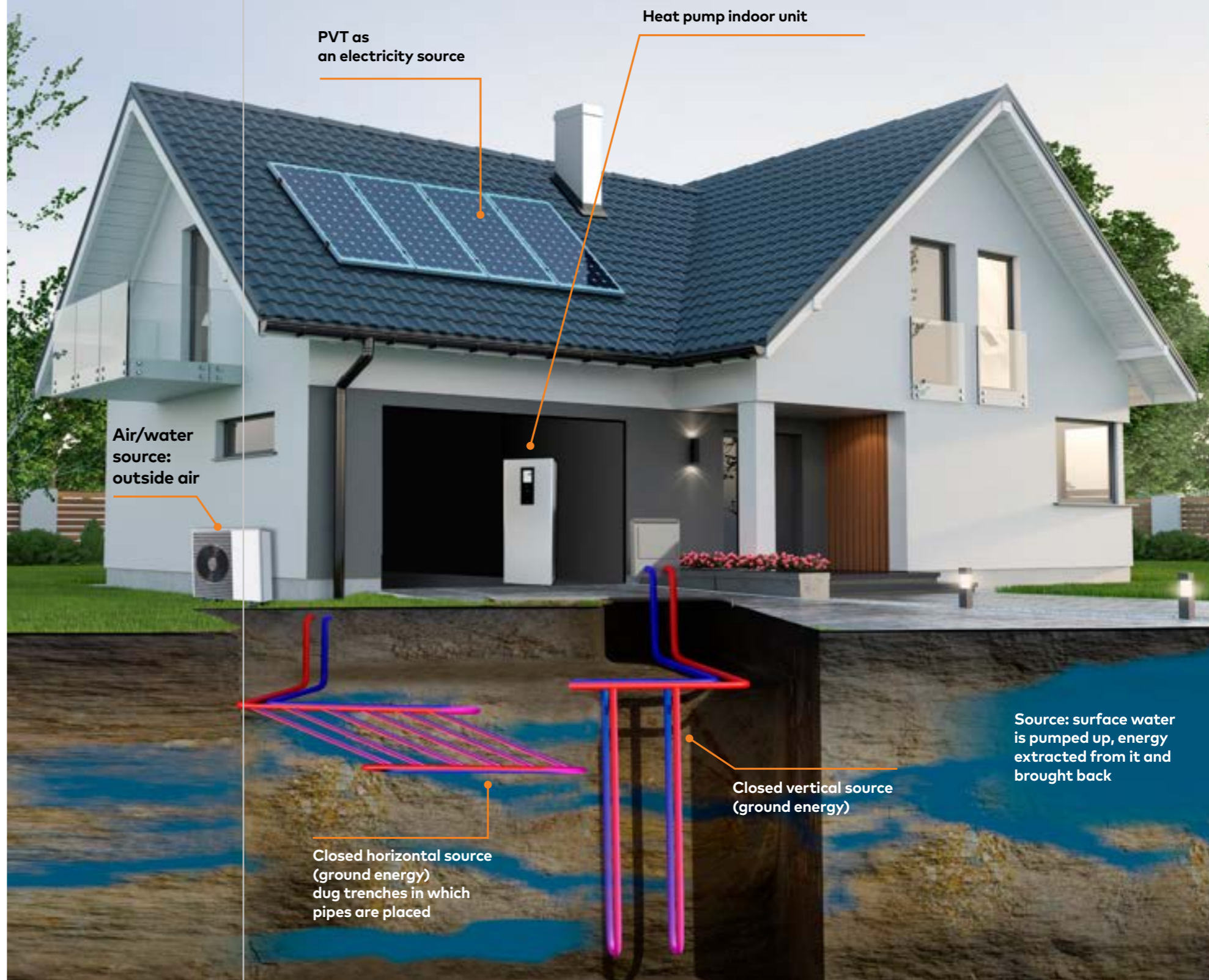

## Measuring & Safeguarding Efficiency

A heat pump's efficiency is measured by its Coefficient Of Performance (COP), which compares the heat output to the electricity input. A higher COP indicates greater efficiency. However, considering the variations in external temperatures throughout the year, it is more practical to refer to the heat pump's Seasonal Performance Factor (SPF) as a measure of its annual performance rate.

To optimise heat pump performance and meet customer expectations, consider the following factors:



### Low temperature conditions

The compressor in the heat pump works harder when there is a significant temperature difference between the heat source and the desired water temperature for radiators or underfloor heating. To enhance efficiency while delivering the required heat output, it is recommended to employ low temperature water systems, such as larger surface area radiators or underfloor heating.



### Hydronic Balancing

To optimise heat pump performance, it is essential to have a properly balanced HVAC system that consistently delivers the appropriate flow to each terminal unit. Quick fixes like raising the temperature curve or pump head should be avoided as they decrease COP and increase energy consumption. For a reliable and efficient solution, consider automatic system balancing using radiator inserts or underfloor heating with Automatic Flow Control technology. These options ensure accurate and automated balancing, regardless of any future system changes.



### Pressurisation & Water Quality

Inadequate pressurisation can cause leakages and air intake, impeding heat transfer and reducing the energy efficiency of heat pumps.

Air presence also contributes to corrosion and debris accumulation, leading to clogs and potential malfunctions or even system failure.

Removing air from heat pump applications can be challenging, particularly in low-temperature conditions (typical supply temperature: 40 °C – 45 °C) where the air is dissolved and difficult to eliminate, especially when combined with underfloor heating. To effectively address air-related issues, it is highly recommended to utilise vacuum degassing equipment along with high-quality expansion vessels.

Choosing the right heat source is essential for optimal HVAC system performance. However, it's equally critical to select the appropriate components like expansion vessels and air & dirt separators and ensure proper system commissioning. These factors are crucial for meeting homeowner expectations and minimising complaints and call-backs.

## Customer Q&A

### Question #1

What does my customer need to consider before installing a heat pump system for heating and cooling?

**Before installing a heat pump system for heating and cooling, there are important considerations that your customer needs to be aware of:**

#### Space

Ensure sufficient outdoor space for the heat pump unit. Proper clearance and airflow are crucial for optimal performance.

#### Insulation and Sealing

Emphasize the importance of good insulation and sealing to enhance efficiency by retaining treated air and reducing energy consumption.

#### Power Supply

Verify if the electrical system can handle the heat pump's power requirements. If necessary, recommend any required upgrades.

#### Climate Considerations

Discuss how different heat pump models cater to various climates. Suggest selecting a model suitable for the region or advise seeking expert guidance.

#### Ductwork (if applicable)

If existing ductwork will be used, ensure its condition. Alternatively, discuss the flexibility of ductless options.

#### Professional Installation

Stress the significance of hiring a certified HVAC professional for safe, efficient, and compliant installation. Explain why a professional's expertise is invaluable.

#### Permits and Regulations

Highlight the necessity of checking local regulations for required permits or approvals. Mention that adhering to guidelines ensures a smooth installation process.

Before proceeding, it can be crucial for HVAC installers like yourself to collaborate with an HVAC professional specialising in heat pump installations. This partnership becomes particularly essential if you lack the necessary experience or expertise to offer comprehensive guidance to your customers. Working alongside a heat pump specialist ensures that your customers receive accurate and informed support throughout the installation process.



**Customer Q&A**

**Question #2**

Can heat pumps be installed in radiator applications?

**Yes, heat pumps can be installed in radiator applications.**

However, it's important to consider that heat pump efficiency (COP) is optimised in low temperature applications. To achieve the same power output at lower temperatures requires higher flow rates and larger radiator surface areas to effectively transfer heat.

Thankfully, modern well-insulated houses have lower power requirements, and therefore existing radiator systems, which are usually oversized to begin with, are still appropriate to meet the flow requirements of the new setup.

To ensure the optimal approach for your customer's installation, we highly recommend utilising the user-friendly Hytools app to help you confidently determine the appropriate radiator size, power output, and flow requirements for the property's specific needs.

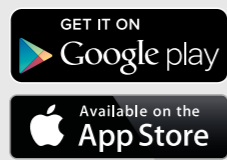

HyTools app is available on AppStore or GooglePlay

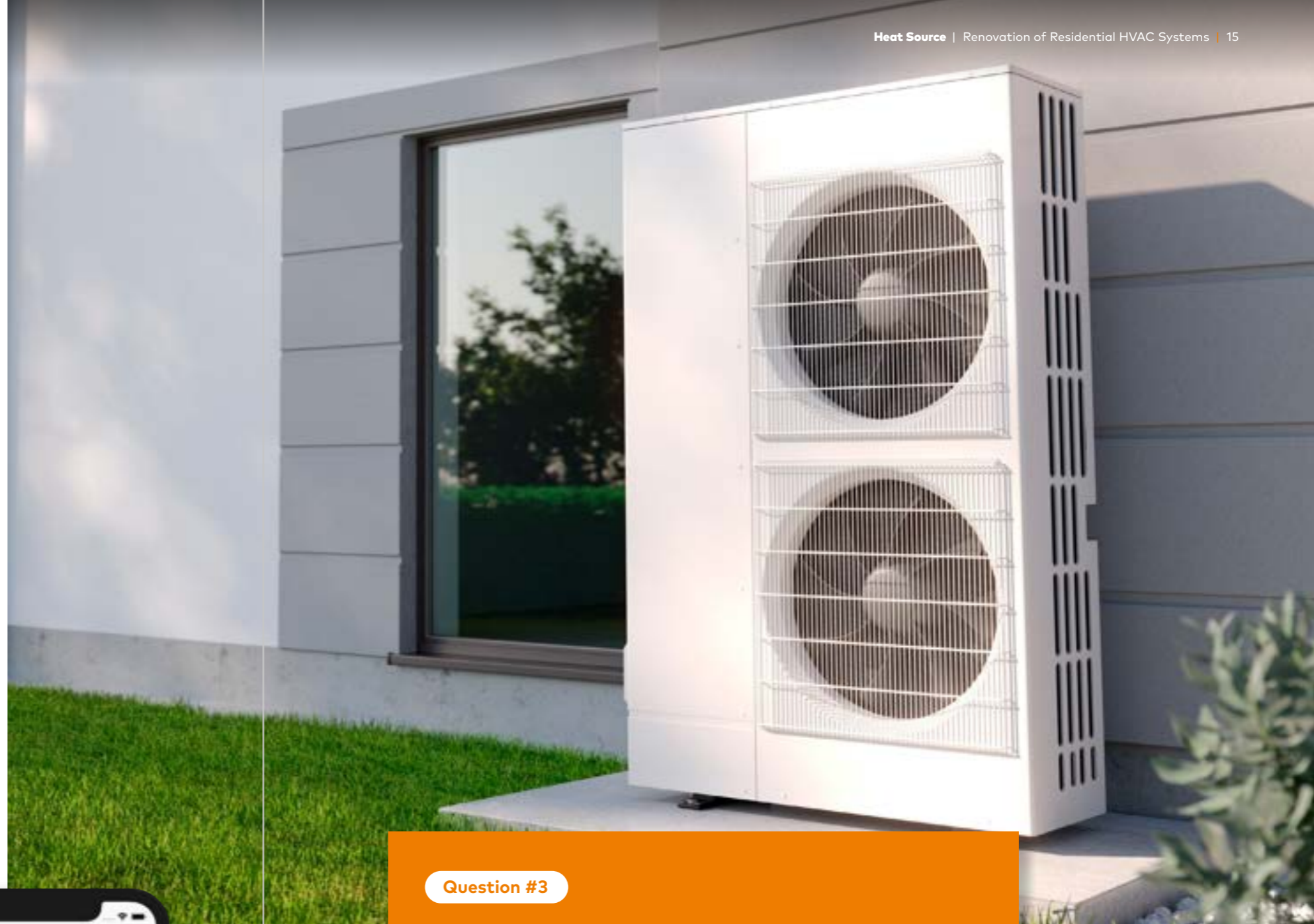
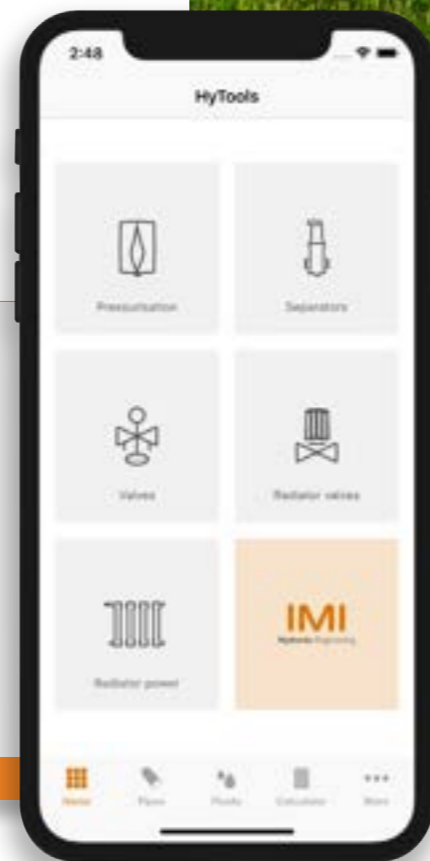

**Question #3**

Can I utilise individual room temperature controls without compromising the efficiency of the heat pump?

For maintaining a stable operating temperature and ensuring comfortable room temperatures, it is recommended to incorporate a buffer tank between the heat pump and the home heating circuit. Installing a properly adjusted **TA STAD balancing valve** between the buffer tank and the heat pump ensures a perfectly balanced flow. The puffer tank effectively compensates for variable flow rates to the rooms, enhancing overall system efficiency.



# Split heat pump system scheme

For a single house

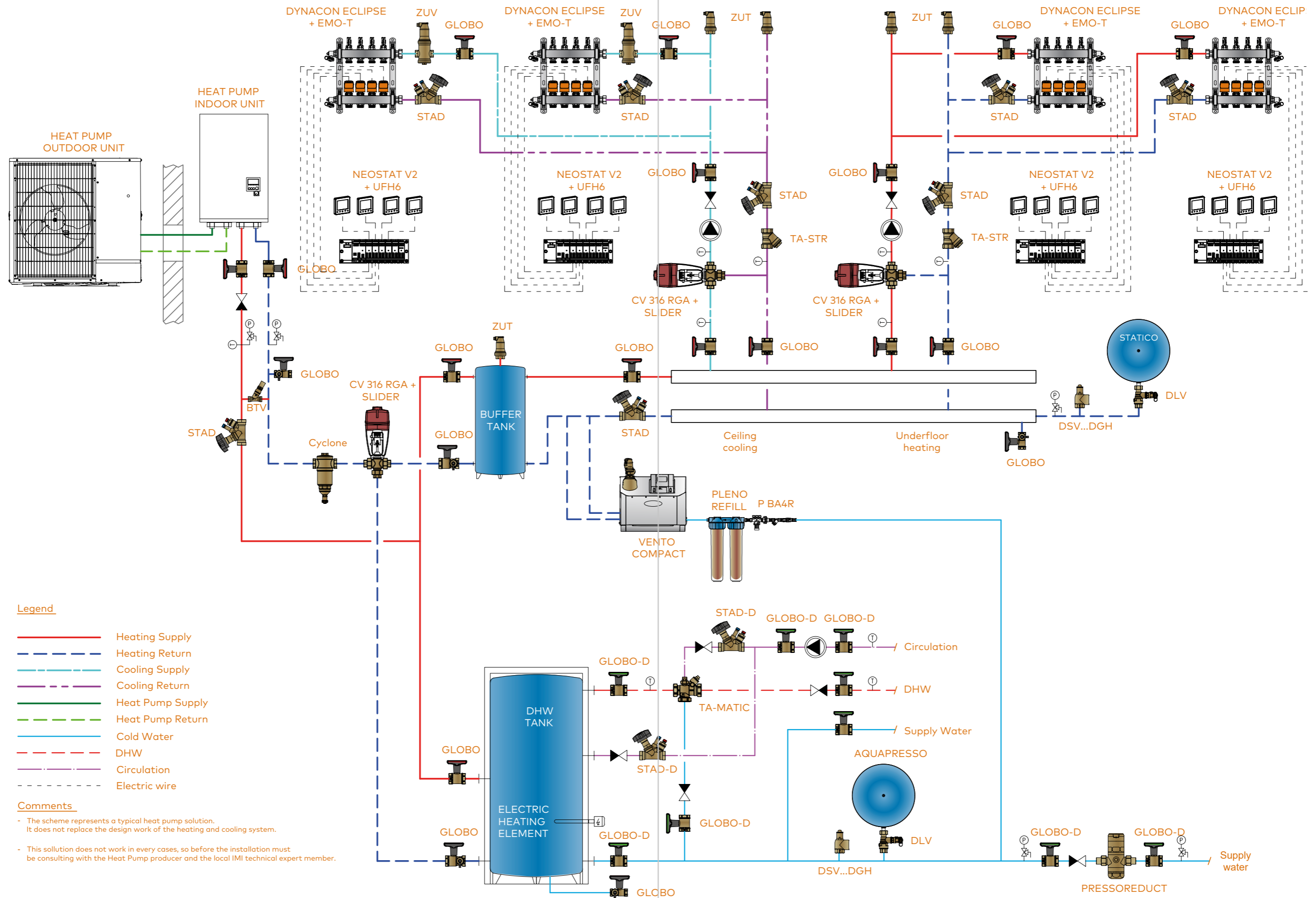

**Legend**

- Heating Supply
- Heating Return
- Cooling Supply
- Cooling Return
- Heat Pump Supply
- - - Heat Pump Return
- Cold Water
- - - DHW
- - - Circulation
- - - Electric wire

**Comments**

- The scheme represents a typical heat pump solution. It does not replace the design work of the heating and cooling system.
- This solution does not work in every cases, so before the installation must be consulting with the Heat Pump producer and the local IMI technical expert member.

# Monoblock heat pump system scheme

For a single house

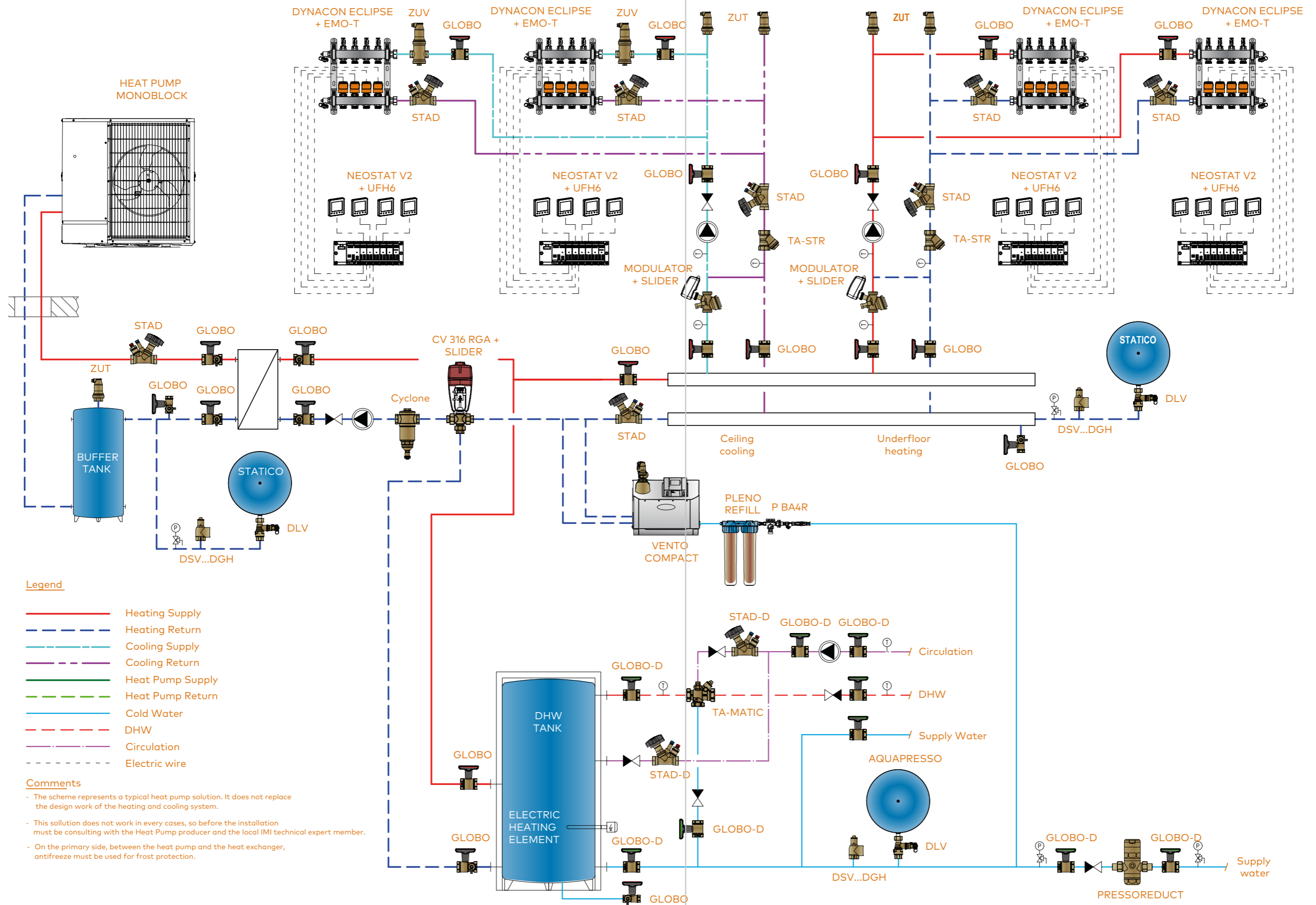

**Legend**

- Heating Supply
- - - Heating Return
- Cooling Supply
- - - Cooling Return
- Heat Pump Supply
- - - Heat Pump Return
- Cold Water
- - - DHW
- Circulation
- - - Electric wire

**Comments**

- The scheme represents a typical heat pump solution. It does not replace the design work of the heating and cooling system.
- This solution does not work in every cases, so before the installation must be consulting with the Heat Pump producer and the local IMI technical expert member.
- On the primary side, between the heat pump and the heat exchanger, antifreeze must be used for frost protection.

# Water-Water heat pump system scheme

For a multi-story building

### Legend

- Heating Supply
- - - Heating Return
- Cooling Supply
- - - Cooling Return
- Heat Pump Supply
- - - Heat Pump Return
- Cold Water
- - - DHW
- Circulation
- - - Electric wire

### Comments

- The scheme represents a typical heat pump solution. It does not replace the design work of the heating and cooling system.
- This solution does not work in every cases, so before the installation must be consulting with the Heat Pump producer and the local IMI technical expert member.
- \* Only a control valve suitable for open loops can be used.

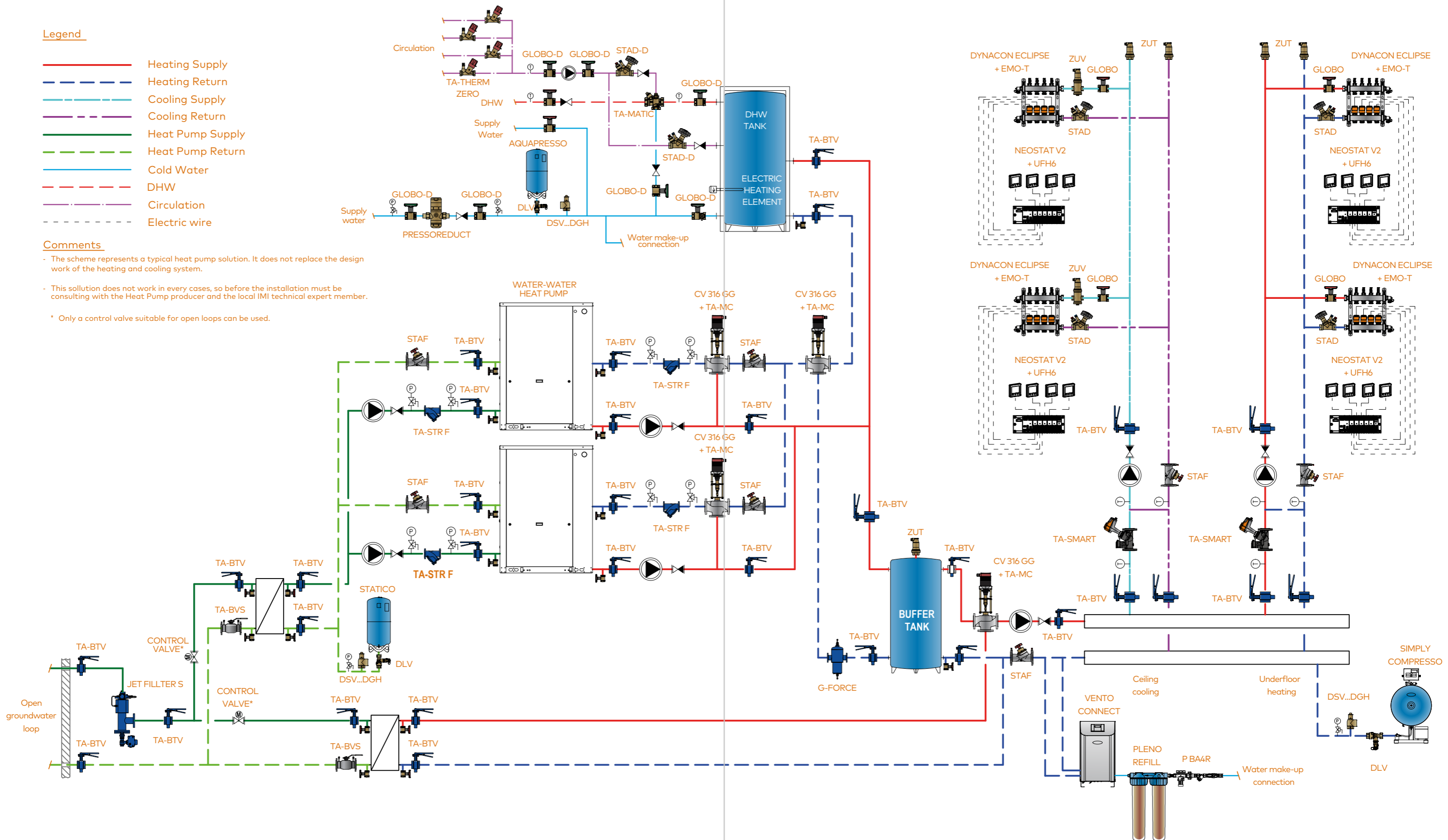

## More on Pressurisation

### | Why it is important?

Maintaining the correct pressure in water-based HVAC systems is crucial due to temperature fluctuations, which cause the fluid volume to expand and contract. Excessive pressure can result in pipe ruptures, while insufficient pressure allows air to enter the system – the biggest threat to the functionality of water-based systems.

### | How does it work?

**Expansion vessels serve two primary purposes:**

#### **Ensuring positive pressure throughout the system**

To prevent air from entering the system, particularly at the highest points where automatic air vents are typically located, it is essential to maintain a minimum overpressure of 0.5 bar, as per EN-12828 standards. This safeguards the plumbing system by preventing the entry of oxygen and nitrogen.

#### **Preventing overpressure**

The air cushion inside the vessel helps balance excess pressure during operation, ensuring that pressure limits are not exceeded and reducing the risk of ruptures or leaks. If pressure becomes excessive, the safety valve opens to release it. On the other hand, when the fluid temperature decreases, a pressure deficit occurs, triggering the automatic water make-up system to replenish the system with fresh water. However, this unintentionally introduces air into the system, leading to a destructive cycle. Implementing a reliable and durable pressurisation system can effectively prevent this issue.



## The bag makes all the difference

Ensuring reliable pressurisation is directly linked to the air cushion's ability to maintain a tight seal and the pressure control's long-term performance.

Our expansion vessels stand out due to their innovative design featuring a specialised bag. Unlike traditional membrane vessels, our vessels prevent water from touching the metal walls of the vessel, ensuring enhanced durability and performance. **Our bag, made of butyl rubber, has the market's lowest air diffusion rate, surpassing any other comparable membrane material by 5 to 10 times.**

This feature ensures that the initial pressure remains largely unaffected, contributing to optimal performance. Most expansion vessels available in the market use a membrane made of EPDM rubber (a type of synthetic rubber), that is more elastic and less resistant to diffusion. As a result, these vessels struggle to maintain the correct static pressure over time.



Learn more  
[imi-hydronic.com](https://imi-hydronic.com)



## Intelligent control

Expansion vessels equipped with software intelligence, such as the unique **BrainCube Connect** control unit, offer advanced connectivity and system monitoring capabilities.

With full access to essential system information via any connected device, computer or smartphone, maintenance crews can receive real-time alerts in case of system failures, allowing them to remotely access settings and make immediate adjustments.

This proactive approach simplifies maintenance, reduces repair costs, and ensures optimal system performance. Additionally, the integration of constant-pressure, variable-volume pressure maintenance systems, controlled by the **BrainCube Connect** and equipped with a compressor, significantly minimises maintenance requirements, further enhancing convenience and efficiency in utilising fixed air cushion vessels.

Learn more  
[imi-hydronic.com](https://imi-hydronic.com)





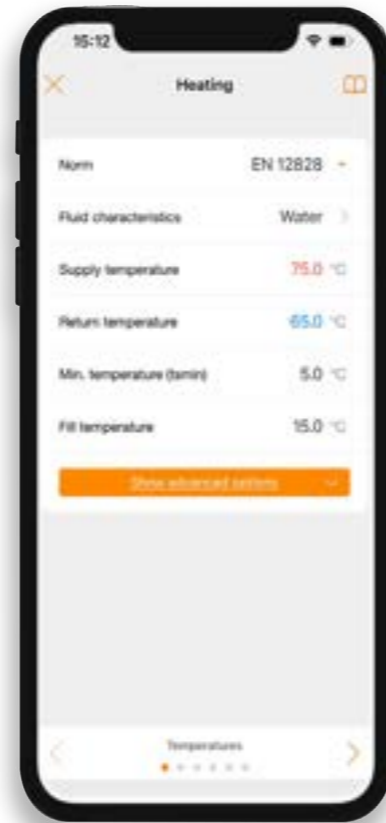

# Choosing the right equipment

When selecting your equipment, you must consider the pressure range in the system. According to the EN-12828 standard, the minimum reserve volume for the expansion vessel should be at least 0.5% of the total installation volume, with a minimum requirement of 3 liters.

To simplify the sizing process, we highly recommend using our user-friendly **HyTools app**. By entering system information such as temperatures, pressures, and water volume, you can determine the most suitable size for your expansion vessel. In case any of these parameters are unknown, it can be easily estimated thanks to our powerful algorithm, built upon years of experience.



## Recommended Solutions

			
Statico	Simply Compresso	Compresso Connect F	Compresso Connect
Pressure expansion vessels with fixed gas charge	Pressure maintenance system with pre-assembled compressor	Pressure maintenance system with one compressor	Pressure maintenance system with compressors
			
<ul style="list-style-type: none"> <li>• From 8L to 5000L</li> <li>• Simple design, robust construction</li> <li>• Operation without auxiliary power</li> <li>• Airproof butyl bag according to EN 13831</li> </ul>	<ul style="list-style-type: none"> <li>• 80L or 160L</li> <li>• Easy and comfortable operation</li> <li>• State-of-the-Art Connectivity</li> <li>• Pressure maintenance with ECO-night mode</li> </ul>	<ul style="list-style-type: none"> <li>• From 200L to 800L</li> <li>• TecBox with one compressor for on top fixation</li> <li>• State-of-the-Art Connectivity</li> <li>• Remote Access and Trouble-shooting</li> </ul>	<ul style="list-style-type: none"> <li>• From 200L to 5000L</li> <li>• Floor standing TecBoxes with one or two compressors</li> <li>• State-of-the-Art Connectivity</li> <li>• Remote Access and Trouble-shooting</li> </ul>

## Customer Q&A

### Question #1

Why should my customer invest in a high-quality expansion vessel?

**Poor pressurisation has serious and expensive consequences. Therefore, it is financially worthwhile to invest in high-quality vessels rather than bearing the costs of equipment repairs and high energy bills.**

When you choose an IMI Pneumatex vessel, you are investing in the reliability of the butyl bag, which boasts the lowest gas diffusion rate in the market. This ensures long-lasting pressurisation performance.

**Our measurements have shown that an IMI Pneumatex vessel loses the same pre-set pressure that competitors lose in 1 year, in almost 10 years!**

By selecting an IMI Pneumatex vessel, your customers can have peace of mind knowing that their equipment is durable and their HVAC system is well-protected. As an installer, the robustness of these vessels safeguards your reputation and ensures that you won't waste time on periodic product replacements, callbacks or unnecessary repairs.

# Tap Water

Domestic hot water production typically accounts for the highest energy consumption and expense on your customers' bill, as heating water to temperatures ranging from 45 °C to 50 °C requires a substantial amount of energy.

The implementation of intelligent practices and optimising the use of tap water can lead to significant energy savings, enhance system performance, and extend the lifespan of your HVAC system.



## Hydronic Balancing

Balancing return water plays a crucial role in optimising the usage of tap water within residential systems. It ensures even distribution throughout the HVAC system, minimising energy loss, and preventing strain. By implementing effective solutions such as flow control devices and pressure-regulating valves, system performance and longevity can be enhanced, providing a consistent water supply.



## Control of Pressure and Temperature

Installing pressure-regulating valves enables effective management of the system's efficiency through stabilising pressure (eliminating damaging water hammer) and reducing water consumption. Additionally, thermostatic mixing valves allow precise temperature control, ensuring comfort and minimising energy expenditure.



## Maintenance and Care

Performing routine tasks like regular flushing, filter cleaning, and pipe inspections helps prevent issues such as mineral deposits and corrosion. By promptly addressing these concerns, the system operates optimally for an extended period.



## Water Quality and Sustainability

By implementing effective filtration and treatment methods, such as the utilisation of eco-friendly water filters and integrating water recycling systems with lead-free components, it becomes possible to prevent impurities from compromising the efficiency of the system. Furthermore, adopting energy-efficient water heating options reduces your environmental footprint but also leads to long-term cost savings.

## Recommended Solutions

TA-Therm ZERO	Aquapresso	Pressoreduct
 <ul style="list-style-type: none"> <li>• Thermostatic circulation valve for automatic balancing in domestic hot water systems</li> <li>• Thermometer</li> <li>• Step-less temperature setting</li> <li>• Lead-free product (&lt;0.1% lead content)</li> </ul>	 <ul style="list-style-type: none"> <li>• Pressure expansion vessels for Domestic Hot Water systems and pressure-boosting systems</li> <li>• From 8L to 3000L</li> <li>• Airproof butyl bag according to EN 13831</li> <li>• Operation without auxiliary power</li> </ul>	 <ul style="list-style-type: none"> <li>• Pressure reducer valve for drinking water supply systems</li> <li>• Protection against extreme supply pressure</li> <li>• Featuring one manometer</li> <li>• DN 15 – DN 50</li> <li>• Max. temperature +40 °C</li> <li>• Min. temperature +5 °C</li> </ul>
Globo D	TA-Mix	TA-Matic
 <ul style="list-style-type: none"> <li>• Drinking water ball valve made of corrosion-resistant gunmetal</li> <li>• Tubular body, ideal for continuous pipe insulation</li> <li>• Operating toggle outside the pipe insulation</li> <li>• Also available in Press version</li> </ul>	 <ul style="list-style-type: none"> <li>• Thermostatically controlled mixing valve</li> <li>• Control of domestic hot water supply or of similar smaller systems</li> <li>• DN 15</li> </ul>	 <ul style="list-style-type: none"> <li>• Thermostatic mixing valve</li> <li>• Control of domestic hot water systems with or without hot water circulation</li> <li>• DN 20-50</li> </ul>

# | Safety Valves

Safety valves play a critical role in the pressurisation system, automatically discharging fluid when the pressure exceeds the preset limit. They serve as a vital protective measure against catastrophic failures.

The installation of safety valves is mandatory according to regulatory standards due to their critical function. In addition, safety valves have to be tested once a year and this has to be recorded. Each country has national regulations that have to be followed on the use and maintenance of safety valves. Additionally, these valves offer a low hysteresis (10% deviation) in comparison to other safety valves available in the market.

IMI Pneumatex safety valves have received official certification and approval in compliance with EN ISO 4126-1:2013, DIN 4751, SWKI HE301-01, and PED 2014/68/EU.

In August 2020, the SICC HE301-01 directive, known as the "Technical Safety Equipment for Heating Installations," came into effect. It specifies that membrane safety valves categorised as "H" or "SOL" should no longer be utilised due to their failure to meet the essential technical safety requirements.

## Recommended Solutions

DSV... H	DSV... DGH	DSV... SOL	DSV... F	DSV... DGF
Safety valve for heating systems	Safety valve for heating, cooling and solar systems	Safety valve for solar systems	Safety valve for cooling systems	Safety valve for heating, cooling and solar systems
				
Min - Max. temperature: -10 °C – 120 °C	Min - Max. temperature: -10 °C – 120 °C	Min - Max. temperature: -10 °C – 160 °C	Max. temperature: 150 °C	Min - Max. temperature: -50 °C – 200 °C

# | Pressure Reducing Valves



Pressure reducing and stabilising valves serve a crucial role in regulating downstream pressure to a desired level. Their primary function is to protect equipment from potential structural damage and minimise noise in the installation, while also effectively absorbing water hammer.

All of IMI Pneumatex pressure reducing valves adhere to the standards of DIN EN 1567, DIN 1988, DIN EN ISO 3822 and PED 2014/68/EU, ensuring compliance and reliability.

These valves excel in their ability to stabilise the outlet pressure without requiring a minimum pressure differential ( $\Delta p$ ) between the outlet and inlet. Furthermore, they effectively absorb water hammer and are compatible with compressed air and neutral gases (such as nitrogen).



## Recommended Solutions

Pressoreduct	Pressoreduct HP threaded	Pressoreduct HP flanged
		
<ul style="list-style-type: none"> <li>• Threaded pressure reducer with balanced seat</li> <li>• Setting scale for trouble-free commissioning</li> <li>• Integrated filter 160 µm easy to clean or replace</li> <li>• Transparent filter cup</li> <li>• DN 15 – DN 50</li> <li>• PN 16 (PN 25*)</li> </ul>	<ul style="list-style-type: none"> <li>• Threaded pressure reducer with balanced seat</li> <li>• Complete with pressure gauge and integrated filter (DN 15 – DN 32 0,60 mm DN 40 – DN 50 0,76 mm)</li> <li>• Complete with male connections</li> <li>• Plug insert available as spare part</li> <li>• DN 15 – DN 50</li> <li>• PN 40</li> </ul>	<ul style="list-style-type: none"> <li>• Flanged pressure stabilising valve with balanced seat</li> <li>• Complete with pressure gauges and integrated filter 0,76 mm</li> <li>• Plug insert available as spare part</li> <li>• DN 65 – DN 100</li> <li>• PN 16</li> </ul>



## More on Water Quality

### Why it is important?

Air is the biggest enemy of water-based heating & cooling installations. When mains water is used for the initial system fill-up and subsequent refilling through the water make-up device, it introduces a significant amount of air due to its open circuit nature. Furthermore, the system may encounter air infiltration during negative pressure conditions caused by factors like poor pressurisation, inadequate water reserve, or incorrect initial pressure.

The presence of air has detrimental consequences, including erosion, corrosion, rust, and the formation of dirt deposits. These deposits can obstruct components, leading to premature failures and reduced system efficiency. Additionally, nitrogen, although less reactive than oxygen, can impede thermal transfer and disrupt hydronic balancing and control, necessitating system readjustment.

Addressing air management through proper pressurisation, adequate water reserves, and degassing of water make-up is crucial for optimising performance, extending system longevity, and preventing costly issues.

### Typical consequences from air & dirt in the HVAC system



## Removing Air

Air can exist in three different states within the system, depending on temperature and water pressure:

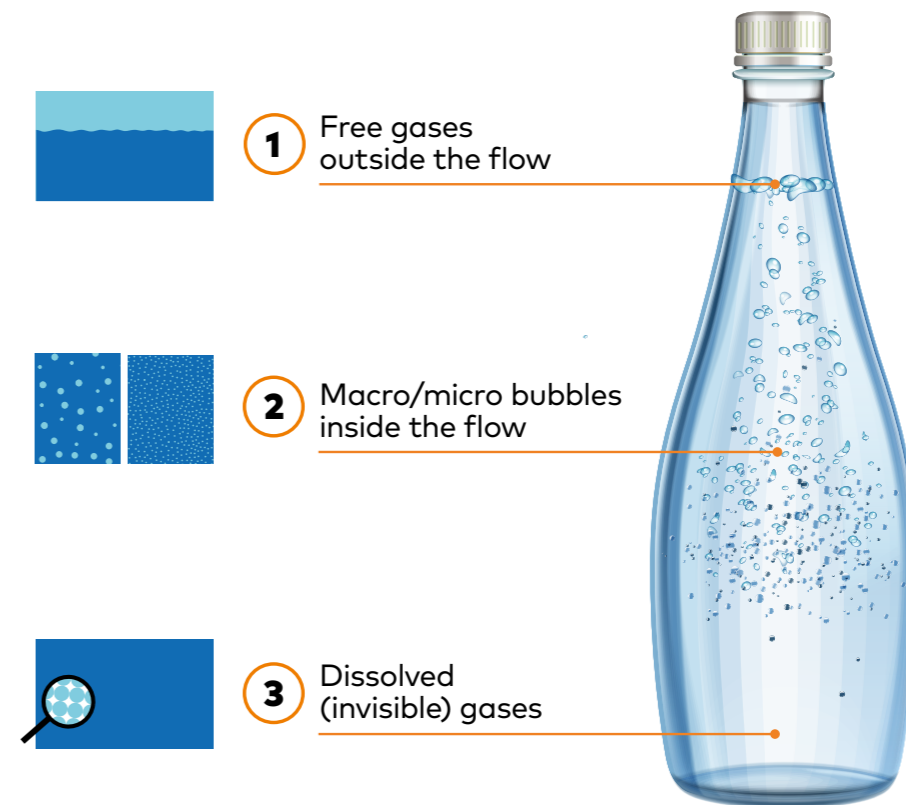

Effectively eliminating air from your HVAC system demands precision, utilising the right combination of products for each air state. Here are three recommended methods for achieving optimal air removal:

### 1 Free gases outside the flow

Air pockets and free gases can be removed by installing **automatic vents** at the highest points of the system, at the top of the main risers, so accumulated air can be evacuated safely and automatically.

These vents are particularly effective at flow speeds of up to 0.3 m/s, so they can be used for venting free gases during system fill-up and commissioning, not as operational venting. You could also place vents in radiators in smaller systems to facilitate operational venting.

Additionally, you may strategically install additional vents in areas where water flow slows down, such as buffers, hydraulic couplings, and manifolds, acting as bonus air separators.

## 2 Macro/micro bubbles inside the flow

The amount of gas bubbles will vary with the changes in system temperature and pressure. To effectively remove both macro and micro bubbles, it is recommended to utilise **air and micro bubble separators** that slow down the flow speed (approximately 0.1 m/s).

The separated bubbles are then expelled by an integrated automatic air vent within the separator device. There are combi versions (air + dirt separators combined) that not only eliminate air bubbles but also recover solid particles that accumulate in the lower part of the unit, and can be removed through a built-in drain.

**Micro bubble separators should be installed at points in the system where bubbles naturally form, typically in the areas with the highest temperature or lowest pressure.**

### How our air and micro bubble separator Zeparo ZUT top works:

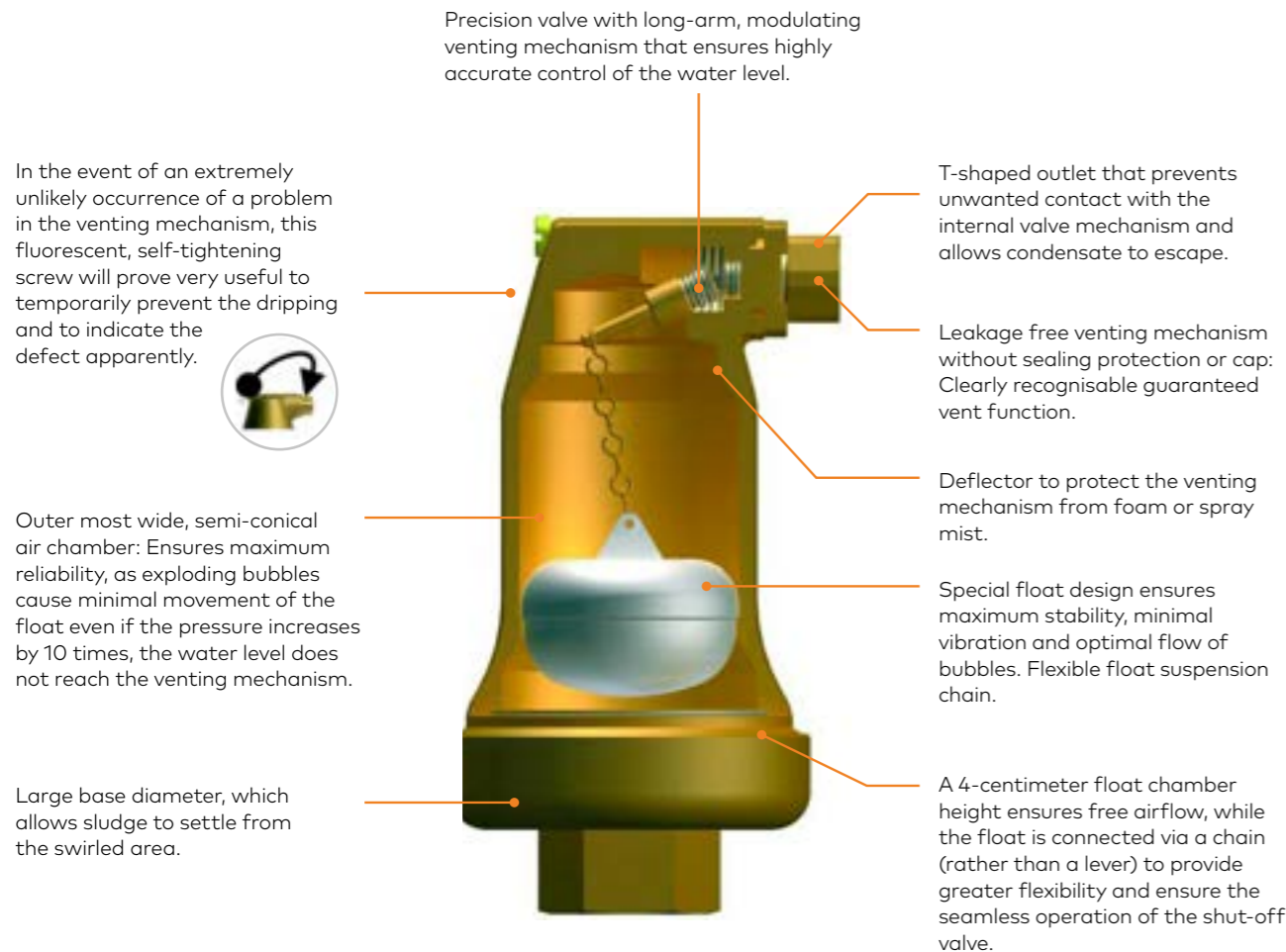

Widest possible insertion diameter: Reduced risk of capillary constipation due to a stagnant bladder (3/8" is a compromise, minimum 1/2" is recommended).

## 3 Dissolved (invisible) gases

To effectively remove dissolved air from both the system's water and the water make-up, it is necessary to use a **vacuum degasser**, which is achieved by reducing system pressure to create a vacuum environment, allowing gases to be released from the water.

This becomes particularly important with the growing installation of heat pumps and underfloor heating systems, as these systems operate at low temperatures, causing air to remain bonded to the water molecules (making it impossible to be separated using microbubble separators or automatic air vents).

IMI Pneumatex utilises a unique technology called cyclonic vacuum degassing, which has the highest efficiency on the market. This technology applies pressure through flow restriction to form a spiral vortex that concentrates the gases where they need to be. As flow speed reduces, air bubbles rise to the surface and can be removed. Vacuum degassers should be installed at the system return, near the expansion vessel and protected by a dirt separator equipped with a strong magnetic rod. The inlet and outlet connections should be at least 500 mm apart (to avoid the degassing of the same water over and over). Depending on the model, the pressure range can vary from 2 to 10 bar (in reality to 20 bar with Vento VI) and temperatures from 5 °C to 90 °C, even though we need to consider that they should be installed on the return (so where the fluid temperature is lower).

To prevent any gas from entering the system, another crucial factor is the water used for replenishing the system, which, as mentioned earlier, is often rich in gases. The water make-up is degassed prior to being introduced into the system, thereby eliminating the gases before they have a chance to enter and initiate corrosion.

### Recommended Solutions

				
Zeparo ZUT	Zeparo ZT turnable	Simply Vento	Zeparo ZIO	Vento Connect
				
<ul style="list-style-type: none"> <li>Automatic air vent</li> <li>Venting and separation of micro bubbles, sludge, oxygen and magnetite</li> <li>Heating, solar and cooling water systems</li> </ul>	<ul style="list-style-type: none"> <li>Venting and separation of microbubbles, sludge, air and magnetite</li> <li>Heating and cooling water systems</li> <li>Custom fit 360°</li> </ul>	<ul style="list-style-type: none"> <li>Compact cyclonic vacuum degasser for heating systems</li> <li>Easy commissioning, Remote Access and Trouble-shooting</li> </ul>	<ul style="list-style-type: none"> <li>Microbubble, dirt and magnetite separator</li> <li>Flanged version</li> <li>Heating, solar and chilled water systems</li> <li>Industrial application</li> </ul>	<ul style="list-style-type: none"> <li>Cyclonic vacuum degassing system with water make-up control</li> <li>Heating, solar and cooling water systems</li> </ul>

# Removing Dirt

When addressing dirt particles in HVAC systems, it is crucial to take into account their composition and size. Relying solely on filters is suboptimal because they only capture the largest particles.

Filters can become clogged with accumulated dirt particles over time, increasing the  $\Delta p$ . Dirt separators on the other hand, effectively maintain particle separation over time, ensuring consistent performance without excessive dirt buildup and therefore don't interfere with the  $\Delta p$ .

The system's water velocity conditions also play a crucial role in determining the efficiency of dirt separation and the appropriate technology for effective particle removal.

## Maximising efficiency at Low flow\* conditions: Helistill Technology

As the flow slows down when entering the separation chamber, the specialised Helistill insert captures dirt particles, allowing them to fall by gravity into a separate chamber. A removable magnet further traps magnetite particles. With the aid of low flow conditions, the Helistill system achieves optimal separation efficiency, leaving your system cleaner and more efficient.



[Learn more imi-hydronic.com](https://imi-hydronic.com)

## Maximising efficiency at High flow\* conditions: Cyclonic Technology

As the flow enters the Zeparo's chamber, a centrifugal force creates a water vortex that forcefully thrusts dirt particles against the outer wall of the separator. Thanks to gravity, these particles naturally descend to the bottom chamber for flushing. The cyclone effect is intensified in higher flow conditions, optimising separation. Cyclonic Technology removes up to 95% of dirt particles, including the smallest ones (5-10  $\mu m$  thanks to the magnet integrated into the insulation shell), in a single circulation, preventing them from circulating and adhering to equipment. It outperforms other manufacturers by 9 times in efficiency.









\*For applications where for most of the season, the flow rate is: <20% of qdesign Zeparo ZT turnable is the best choice. >60% of qdesign, Cyclonic technology is the best choice. Between 30%-60% of qdesign, both technologies yield excellent results

[Learn more imi-hydronic.com](https://imi-hydronic.com)



our Cyclonic demo unit capturing dirt particles

## Recommended Solutions

			
Zeparo ZT turnable	Zeparo Cyclone	Zeparo ZIO	Zeparo G-Force
			
<ul style="list-style-type: none"> <li>• Venting and separation of microbubbles, sludge, air and magnetite</li> <li>• Heating and cooling water systems</li> <li>• Custom fit 360°</li> </ul>	<ul style="list-style-type: none"> <li>• High efficiency dirt separator</li> <li>• Cyclonic separation technology</li> <li>• Heating and cooling water systems</li> <li>• Horizontal and vertical mounting</li> </ul>	<ul style="list-style-type: none"> <li>• Microbubble, dirt and magnetite separator</li> <li>• Heating, solar and chilled water systems</li> <li>• Industrial application</li> <li>• Flanges PN 16 according to EN 1092-1.</li> <li>• Specifically designed for large installations</li> </ul>	<ul style="list-style-type: none"> <li>• High efficiency microbubble, dirt and magnetite separator</li> <li>• Cyclonic separation technology</li> <li>• Heating and cooling water systems</li> <li>• Flanges PN 16 according to EN 1092-1</li> </ul>

## Customer Q&A

### Question #1

Why should my customer invest in vacuum degassers instead of just air vents?

Due to the growing use of heat pumps and underfloor heating, HVAC systems now operate at lower temperatures, leading to increased adhesion between air and water molecules. Removing air from the system under these conditions becomes challenging due to the spiral construction of underfloor heating systems, which prevents air from rising and accumulating at the surface. As a result, conventional separators such as air vents or microbubble separators are mostly ineffective.

Here, you can see the conditions in which degassers are preferable to separators:

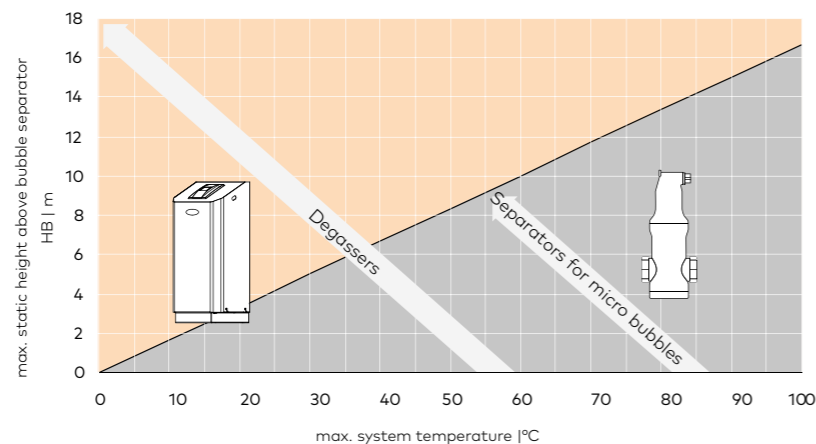

The lower the temperature or the static height, the more air will be trapped into the molecule and therefore degassers are the only effective method to remove air, which employ under-saturation to release dissolved gas. A notable advantage of this method is that the water, because it is continuously under-saturated, displays a strong affinity for air and will attempt to capture it whenever it encounters it as it circulates through the system.

Well-designed vacuum degassing equipment can effectively degas the entire system within two weeks, even in large-volume applications. To prevent air from continually flowing into the system through the make-up water, it is essential that the vacuum degasser also integrates the make-up management, so that air can be degassed before it is loaded into the system.

### Question #2

Why should my customer invest in high-quality dirt separators, instead of cheap solutions?

The presence of dirt leads to several negative consequences for homeowners:

- **Reduced indoor comfort**

Dirt creates an insulating effect, impairing effective heat transfer and preventing terminal units from delivering the desired temperature, thereby affecting overall indoor comfort.

- **Increased energy costs**

Decreased heat transfer results in reduced energy efficiency. Even a single millimeter of scale deposit can increase boiler energy consumption by up to 9%.

- **Shortened system service life and costly repairs**

Corrosion damages expensive metal equipment, while magnetite and dirt particles circulate in the system, accumulating in valves and pumps and causing blockages, failures, and ultimately expensive premature repairs.

Cheap separators typically have filters that cannot capture small dirt particles, which are often responsible for causing significant damage. Additionally, they are equipped with low-quality magnets or lack them entirely, making them ineffective at capturing magnetite.

**High-quality separators swiftly remove dirt before it can circulate and cause damage.**

They are cleverly designed to capture even the smallest particles (5-10  $\mu\text{m}$ ) and feature strong magnets. Their engineering prevents clogging and blockages, maintaining optimal flow, preventing resistance and pressure drops, and ultimately enhancing energy efficiency while preventing ruptures and leaks.

Considering the short-term and long-term issues caused by dirt in HVAC systems, it is financially worthwhile to invest in quality equipment rather than bearing the costs of equipment repairs and high energy bills. Prevention is always better than expensive remedies!

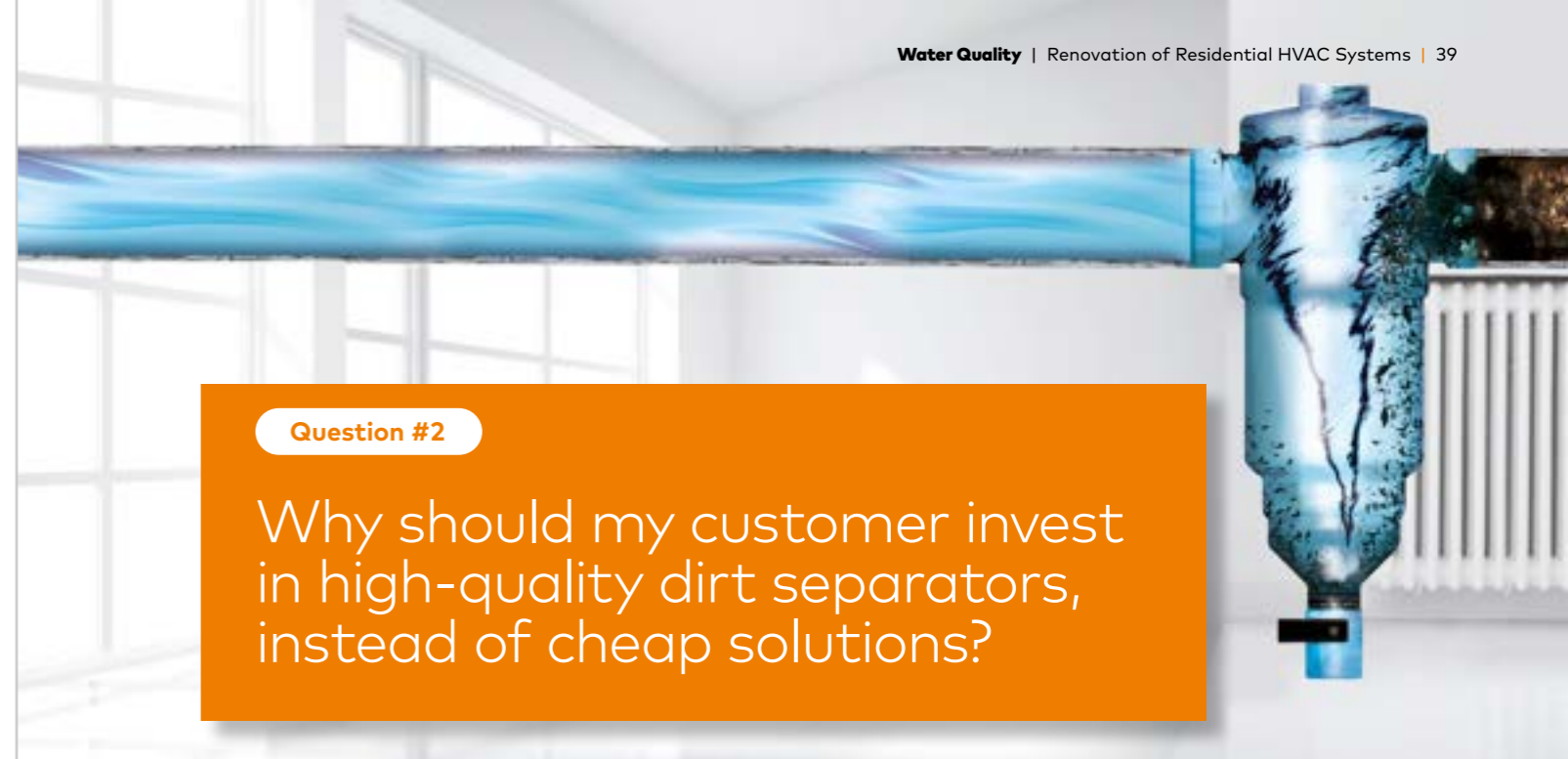

# More on Hydronic Balancing

Hydronic balancing is the essential process of managing pressure throughout the system to ensure that each terminal unit in the hydronic network receives its required flow consistently. It involves using balancing valves to regulate and control the flow, which needs to be calculated during the initial installation, commissioning, or as a retrofit measure to enhance the performance of existing systems.

## Why is hydronic balancing important?

### 1 Comfort

Water's tendency to follow the path of least resistance has a direct impact on heating systems. Without proper hydronic balancing, the terminal units closest to the heat source receive an excess of flow, resulting in noise and inadequate heat distribution. Simultaneously, insufficient heat distribution occurs in units located farther from the heat source, causing a significant drop in room temperature and an inability to reach the desired temperature. These issues inevitably result in customer complaints.

### 2 Energy efficiency

Proper heat distribution ensures that all rooms reach their desired ambient temperature. On the other hand, an unbalanced system causes significant temperature fluctuations, resulting in expensive discomfort. In fact, just a one-degree variance in the ambient temperature can result in a 6% to 11% rise in energy consumption. However, by balancing the system, on average, you can achieve energy savings ranging from 20% to 35%.

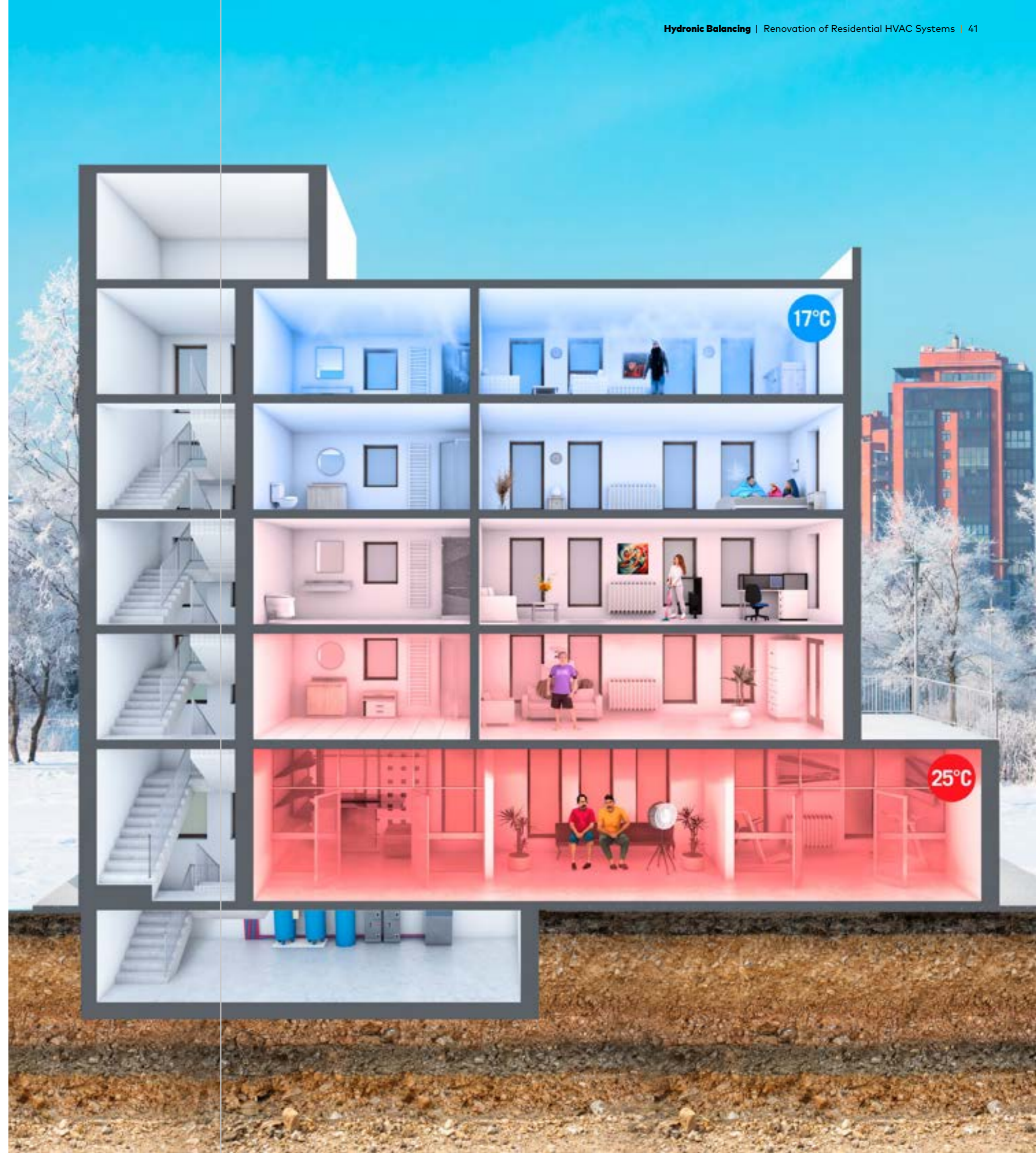



## How to solve it?

Attempts such as using additional boilers, increasing pump head, or adjusting the supply temperature are ineffective and can lead to further problems, including noisy pipes, higher energy costs, and compromised heat distribution. Moreover, increasing the pump head by 20% to compensate for reduced flow can significantly increase the pump's total electricity consumption, sometimes by up to 95%!

The most effective solution for achieving optimal system performance is hydronic balancing. This involves two essential steps: accurately calculating the desired heat load and determining appropriate flow rates for terminal units. By carefully evaluating these factors, we can precisely adjust the balancing valves to regulate flow rates and pressures in different sections or branches of the system.

Through iterative adjustments of these balancing valves, we work towards achieving the desired balance, ensuring that each room receives the necessary amount of heat. This meticulous approach guarantees consistent heat distribution across the entire system, effectively eliminating temperature variations and delivering superior comfort to occupants.

To be able to hydronically balance an existing system you need to follow the below procedure using the **HyTools app**:

- 1 Identify the radiator type and calculate its heating load.
- 2 Document the temperature regimes and determine the required flow rate.
- 3 Determine the pump head of the circulation pump.
- 4 Ensure the available differential pressure is around 15kPa for each branch, considering the pipe length.
- 5 Set the balancing valves accordingly and consider adding a differential pressure controller if necessary.



However, measuring and recording these values can be time-consuming, especially in older HVAC systems where radiators are often extensively branched, making it challenging to understand the flow requirements in different sections or radiators.

Moreover, accurate drawings of the HVAC system are often unavailable, making calculations of network resistance and output requirements nearly impossible.



Fortunately, intelligent flow control technologies like Automatic Flow Control (AFC) eliminate the need for complex calculations in hydronic balancing.



AFC automatically adjusts the design flow independently based on differential pressure variations, saving time, and offering cost-efficient solutions.

In modern residential buildings, variable-flow systems with Automatic Flow Control technologies have become the standard. These systems allow for flow regulation based on the current demand of end users, ensuring optimal performance.

Learn more  
[imi-hydronic.com](https://imi-hydronic.com)

Dynamic balancing is achieved using automatic thermostatic radiator valves, eliminating the need for sub-vertical fittings. Instead, the installation of STAD manual valves at branches serves as verification points for flow or pressure.

## Recommended Solutions

Dynacon Eclipse UFH Manifold	Eclipse Thermostatic radiator valve	STAD balancing valve
		
<ul style="list-style-type: none"> <li>• Floor heating manifold with automatic flow control</li> <li>• Automatic hydraulic balancing</li> <li>• Flow indicator for each heating circuit</li> <li>• Made of stainless steel</li> </ul>	<ul style="list-style-type: none"> <li>• Thermostatic radiator valve with automatic flow limitation</li> <li>• Heating and cooling systems</li> <li>• Flow range from 10 to 150 l/h</li> <li>• DN 10-20; PN 10</li> <li>• Perfect for renovation</li> </ul>	<ul style="list-style-type: none"> <li>• Accurate balancing and flow reading</li> <li>• Heating, cooling and tap water systems</li> <li>• DN 10-50</li> <li>• Self-sealing measuring points</li> </ul>

## Customer Q&A

### Question #1

How do window replacements and insulation installations impact hydronic balancing?

Replacing windows and installing insulation directly impact the heat gain or loss properties of a home, altering the thermal needs and required load for each terminal unit, which in turn changes the design flow requirement for radiators or underfloor heating.

To maintain proper hydronic balancing, adjustments may be necessary within the HVAC system. This could involve modifying the flow rate in specific zones or adjusting temperature setpoints accordingly.

Moreover, it may be crucial to upgrade or replace specific HVAC components, such as control valves, to ensure the system effectively adjusts to changes in the building envelope and avoids unnecessary energy loss.



### Question #2

Why do some room radiators feel warm while others remain cold?



In a heating system, water naturally takes the path of least resistance. Without proper hydronic balancing, excessive flow goes to radiators in rooms near the heat source, causing overheating, while rooms farther away receive insufficient flow, resulting in uneven temperatures and uncomfortable indoor climates. Imbalanced systems not only cause discomfort but also affect maintenance and energy costs.

**A mere 1°C deviation from the desired room temperature (whether too high for heating or too low for cooling) can lead to energy wastage of up to 11% !**

Moreover, quick fixes like installing larger pumps or raising the supply temperature only exacerbate the problem, leading to issues like noisy pipes, greater energy expenses, and compromised heat distribution.

Maintaining the appropriate balance in your customer's system is key for achieving consistent temperature distribution throughout the property and preventing customer complaints and callbacks.

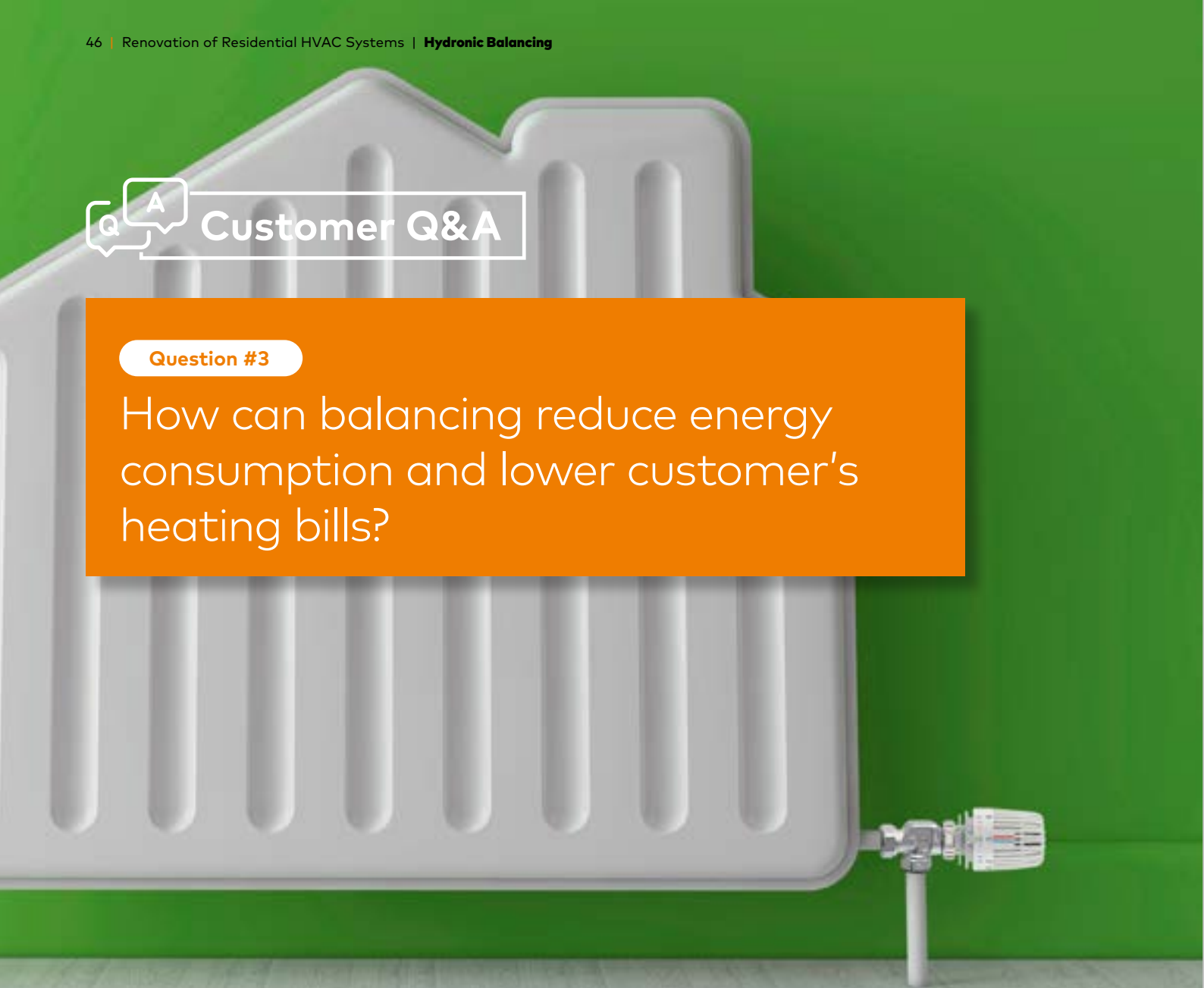
 A white radiator is shown against a green background. The radiator has a classic design with vertical fins. A white pipe is connected to the bottom right of the radiator.
 

## Customer Q&A

### Question #3

How can balancing reduce energy consumption and lower customer's heating bills?

Proper heat distribution in a system can lower the average temperature.

**With each degree of temperature reduction, the property's energy consumption decreases by approximately 6% to 11%.**

Balancing techniques often lead to significant energy savings, typically ranging from 20% to 35%. The payback period for such investments is usually between six months and a year.

A 2022 independent study conducted by WaterBalans in the Netherlands analysed 700 recently upgraded homes. These homes were equipped with Eclipse TRVs (Thermostatic Radiator Valves), Thermostatic K-heads, and underwent hydronic balancing. The study demonstrated an average energy savings of 27%. Notably, a subset of homes that made lifestyle changes, such as unblocking radiators and adjusting K-heads to setting #3, achieved even higher energy savings, up to 50%.

Correctly balanced systems not only consume less energy but also enhance tenant comfort, improving their overall quality of life.

 A woman with long brown hair is sitting on a grey couch. She has her hands on her head and a pained expression, suggesting she is experiencing discomfort or noise.
 

### Question #4

Why is my customer's HVAC system making noise?

System noise can be highly disruptive and is often caused by vibrations in valves and pipework. This can be attributed to:

- Air and dirt circulating in radiators and pipes
- High flow speed
- Excessive pressure drop in valves

**Air vents, dirt separation, and degassing solutions** help maintain a clean system and prevent the formation of air bubbles that can contribute to system noise when passing through valves and radiators.

Additionally, implementing **balancing techniques** will optimise pressure drops in the system, effectively avoiding excessive pressure drops across valves. These solutions not only result in a quieter HVAC system but also enhance its overall performance and efficiency, creating a high-performing heating and cooling system.



## More on Thermostatic & Room Control

Once the HVAC system is properly balanced and all terminal units receive their designated flow, high-quality thermostatic and room control solutions ensure precise delivery of the desired indoor temperature, adapting to real-time conditions.

### For radiators: Thermostatic Head + Thermostatic Valve

Radiator systems utilise thermostatic control, which involves a radiator head and radiator valve. The thermostatic head incorporates an expanding element that autonomously adjusts the radiator valve, enabling it to open or close and regulate the heat output.

This adjustment relies on the differential temperature between the user-defined temperature (set on the radiator head) and the actual room temperature (measured by the sensor inside the radiator head).



### For underfloor heating (UFH): Wall thermostat + Underfloor Heating Manifold

Radiant surfaces, such as underfloor heating, utilise room control, which includes a wall thermostat and an underfloor heating manifold.

The UFH manifold responds to external signals and dynamically adjusts the setpoint to compensate for the temperature difference between the user-defined temperature (set on the wall thermostat) and the actual room temperature (measured either on the wall thermostat or by an external sensor).





# Thermostatic Head

## What makes our Thermostatic radiator heads so unique:

- 

**1** Liquid-filled thermostat allows for precision control and stable temperature regulation
- 

**2** Limiting or locking of a setting allows to set maximum and minimum temperatures and helps to reduce heating costs
- 

**3** Superior pressure power and a strong spring ensure the valve will not stick after non-use during the summer months
- 

**4** The never changed **M30x1,5** connection ensures that every IMI Heimeier sensors fits any valve we have ever produced
- 

**5** Designed and manufactured in Germany for highest quality standards. IMI Heimeier Thermostatic Head are built with highly resistant materials to guarantee constant quality and an extended life cycle of our products. 3rd party certifications and performance control guarantee an optimal user experience

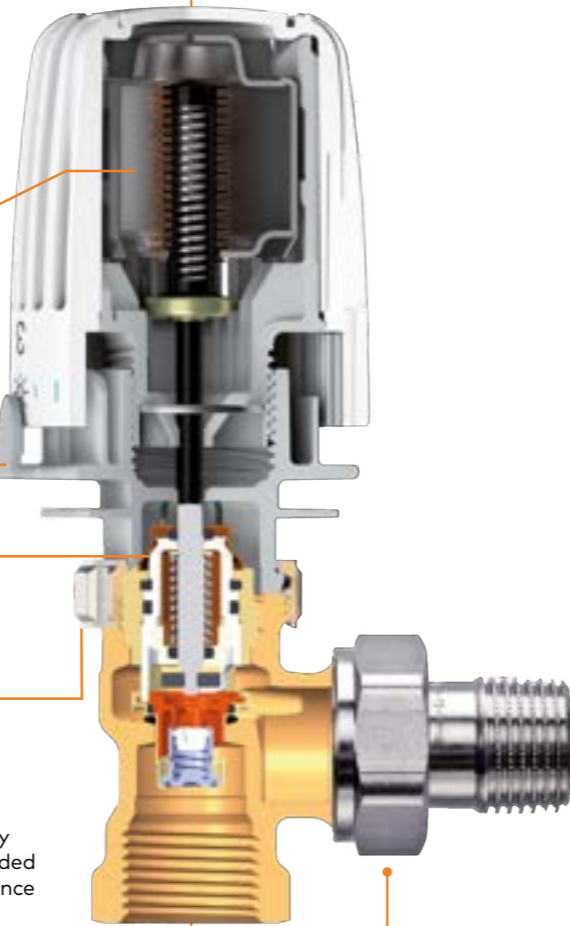

 Certified and tested by KEYMARK in accordance with DIN EN 215 (Series D and F)  
011 KEYMARK symbol approval number 011-6T 0006

 Compatible with European Energy Performance of Buildings Directive (EPBD). Allows to achieve energy savings by optimising and regulating system performance



## Recommended Solutions

Thermostatic head K	Thermostatic head DX	Thermostatic head Halo
		
<ul style="list-style-type: none"> <li>• Heating systems</li> <li>• Liquid-filled thermostat with high pressure power and precision control</li> <li>• With built-in sensor and remote sensor</li> </ul>	<ul style="list-style-type: none"> <li>• Heating systems</li> <li>• Liquid-filled thermostat with built-in sensor, high pressure power and precision control</li> <li>• Particularly suitable for hygienically demanding areas</li> </ul>	<ul style="list-style-type: none"> <li>• Heating systems</li> <li>• Liquid-filled thermostat with built-in-sensor, high pressure power and precision control</li> <li>• Particularly suitable for hygienically demanding areas.</li> <li>• Slim, cylindrical design</li> </ul>

# Thermostatic Valve

## What makes our Thermostatic radiator valves so unique:

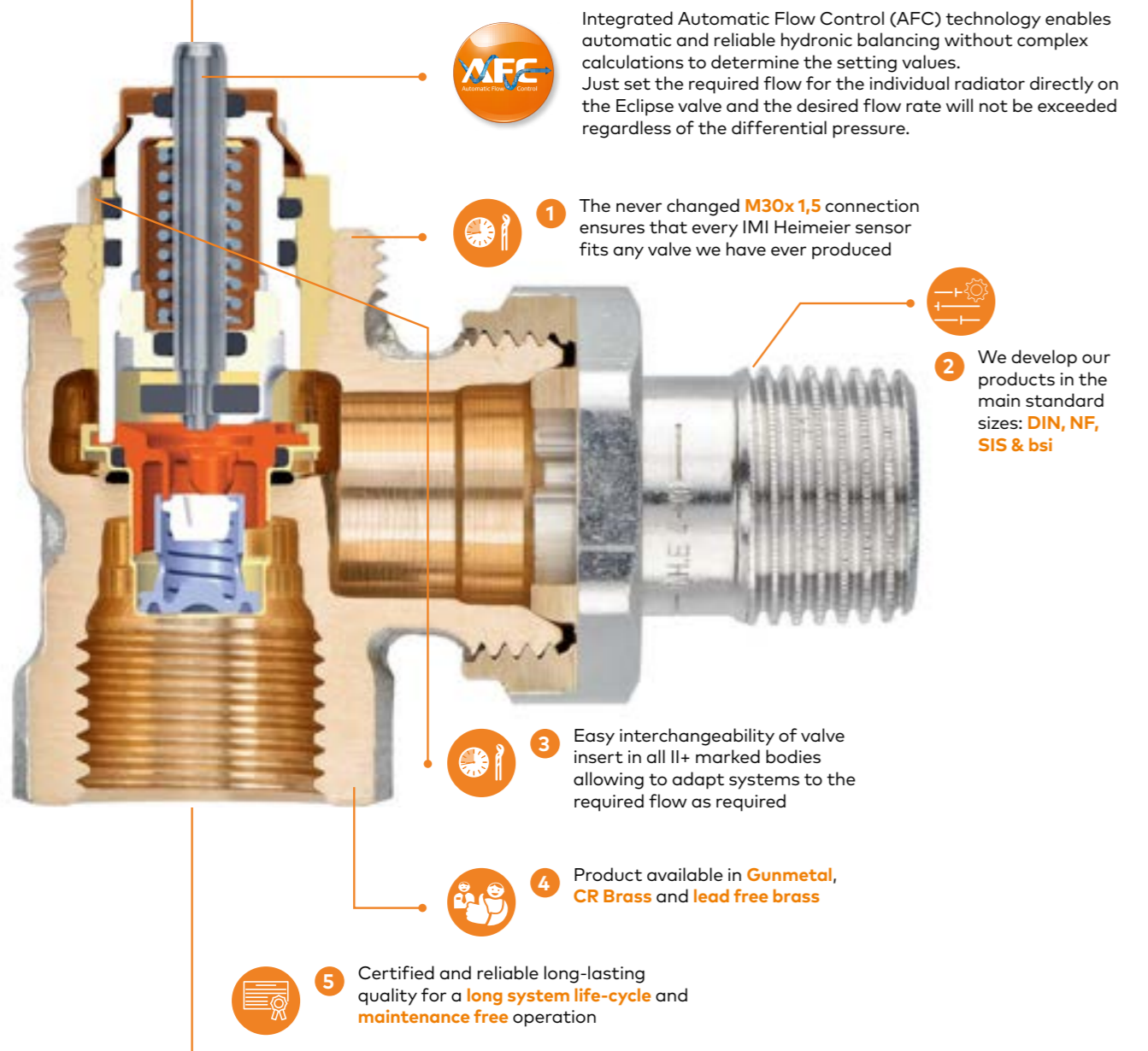



**AFC**  
Automatic Flow Control

Integrated Automatic Flow Control (AFC) technology enables automatic and reliable hydronic balancing without complex calculations to determine the setting values. Just set the required flow for the individual radiator directly on the Eclipse valve and the desired flow rate will not be exceeded regardless of the differential pressure.

- 1 The never changed **M30x1,5** connection ensures that every IMI Heimeier sensor fits any valve we have ever produced
- 2 We develop our products in the main standard sizes: **DIN, NF, SIS & bsi**
- 3 Easy interchangeability of valve insert in all II+ marked bodies allowing to adapt systems to the required flow as required
- 4 Product available in **Gunmetal, CR Brass** and **lead free brass**
- 5 Certified and reliable long-lasting quality for a **long system life-cycle** and **maintenance free** operation



## Recommended Solutions

Eclipse Thermostatic radiator valve	Multilux V Eclipse
	
<ul style="list-style-type: none"> <li>• Thermostatic radiator valve with automatic flow limitation</li> <li>• Heating and cooling systems</li> <li>• Flow range from 10 to 150 l/h</li> <li>• DN 10-20</li> <li>• Easy adjustment</li> <li>• Perfect for renovation</li> </ul>	<ul style="list-style-type: none"> <li>• Two pipes heating systems</li> <li>• Used as a thermostatic valve or as a connection fitting for radiators with integrated valves.</li> <li>• Integrated flow limiter</li> <li>• Interchangeable thermostatic insert and shut-off insert</li> <li>• Suitable for R1/2 and G3/4 connection</li> </ul>



Compatible with European Energy Performance of Buildings Directive (EPBD). Allows to achieve energy savings by optimising and regulating system performance



KEYMARK certified and tested according to EN 215, series S. Connection to thermostatic head: M30x1.5 011

# Underfloor Heating (UFH) Manifold

## What makes our UFH manifold so unique:



### Automatic Hydraulic Balancing

The required flow rate is set directly at the loop and will be automatically regulated. It will not be exceeded even when closing neighboring circuits.



### Settings easy to check

Scaling in l/h Floor heating circuit manifolds are available for flow rates from 10-300 l/h



### Complex calculations are no longer necessary:

Ideal for renovations in unknown heating circuit lengths or widely branched pipe systems.





**Manifold made of stainless-steel**  
corrosion-resistant, durable and safe



Compatible with European Energy Performance of Buildings Directive (EPBD). Allows to achieve energy savings by optimising and regulating system performance

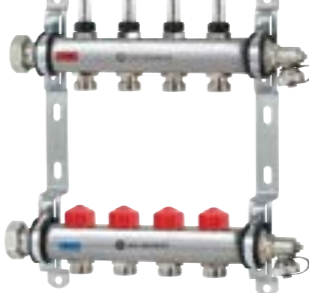

## Recommended Solutions

Dynacon Eclipse	Dynacon 150	Compact-DP
		
<ul style="list-style-type: none"> <li>• Floor heating manifold with automatic flow control</li> <li>• Floor heating systems</li> <li>• Automatic hydraulic balancing</li> <li>• Flow indicator for each heating circuit</li> <li>• Manifold made of stainless steel</li> </ul>	<ul style="list-style-type: none"> <li>• Floor heating manifold with automatic floor control</li> <li>• Floor heating systems</li> <li>• Automatic hydraulic balancing</li> <li>• Perfect for low flows</li> <li>• Made of stainless steel</li> </ul>	<ul style="list-style-type: none"> <li>• Combines 5 functions in 1 valve: differential pressure control, balancing, control, diagnostics and shut-off.</li> <li>• Connection set can be connected to any standard UFH manifold and thus the hydraulic balancing is ensured.</li> </ul>

# Wall Thermostats

## What makes our wall thermostats so unique:



**Energy-Saving Optimum Start**  
Calculates the heat-up time required for a warm home upon return. Those times are optimised throughout the year to save energy.



**Multi Zone Control**  
Control up to 32 zones around the home from anywhere.





**Fail safe** in case of wireless connection loss heats home for 20% of the time, preventing risk of frost damage.



**Geo Location**  
An ideal energy saver – the heating automatically turns off when the homeowner leaves, and back on again once they return.

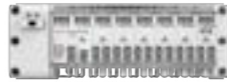

## Recommended Solutions

Wired System		Wireless System	
neoStat	UH6 compact Wiring center	neoAir	UH8-RF V2 wireless wiring center
			
<ul style="list-style-type: none"> <li>• Standalone thermostat that can be paired with neoHub when Smart Control is required</li> <li>• Model for conventional heating</li> <li>• Wired</li> <li>• 3A switch (pure resistive loads)</li> <li>• Supply: 230VAC</li> <li>• Output: Volt free contact (exists with changeover contact neoStat-hw, not for FR and DE)</li> <li>• Minimum wiring requirement: 3 core excluding earth: L, N, LS</li> </ul>	<ul style="list-style-type: none"> <li>• Compact wiring centre</li> <li>• 6zone 230V wiring, compatible with 230V Thermostats</li> <li>• 6zones, each 4 actuators</li> <li>• Heat and pump</li> <li>• Heat and pump Delay Function</li> <li>• Maximum of 5A load</li> </ul>	<ul style="list-style-type: none"> <li>• Wireless design for easy installation</li> <li>• Model for radiator or wet underfloor heating.</li> <li>• Wireless connection</li> <li>• 4 AAA Batteries, 1 year battery lifetime</li> <li>• Compatible with 2channel RF switch and 8 zone UH8-RF and neoHub mini</li> <li>• Wired remote sensor option (fully configurable)</li> </ul>	<ul style="list-style-type: none"> <li>• Wireless 230V 8 zone wiring centre</li> <li>• 8 zones + output for hot water cylinder</li> <li>• 230V output to switch relevant zone actuators, underfloor heating pump and valve.</li> <li>• Creepage function</li> </ul>



**Easy installation and configuration**  
Compatible with smart home systems, including Apple HomeKit, Google Assistant, Amazon Alexa, IFTTT



A new level of underfloor heating technology from Heatmiser, a leading UK manufacturer that joined IMI HE in 2022

## Customer Q&A

### Question #1

Why do radiator thermostatic valves get stuck, how can they be easily repaired, and what preventive measures can be taken?

### IMI Heimeier Radiator Thermostatic Valves (TRVs) do not stick, but it can happen with valves from other manufacturers due to various factors.

Understanding how they work can help in their repair and prevention. A TRV consists of a control valve (radiator valve/valve base) and a controller (thermostatic head/upper part).

It operates based on the surrounding temperature (room temperature), regulating the flow independently without external energy requirements.

A thermostatic head contains an expansion element (liquid, wax, or gas) that expands or contracts with the room temperature. This element applies pressure on the valve spindle and the valve cone, which closes the valve when the desired temperature is reached and opens it again when the temperature falls below the set point. A mechanical spring assists in the opening and closing process, with its strength determined by the type of expansion element used.

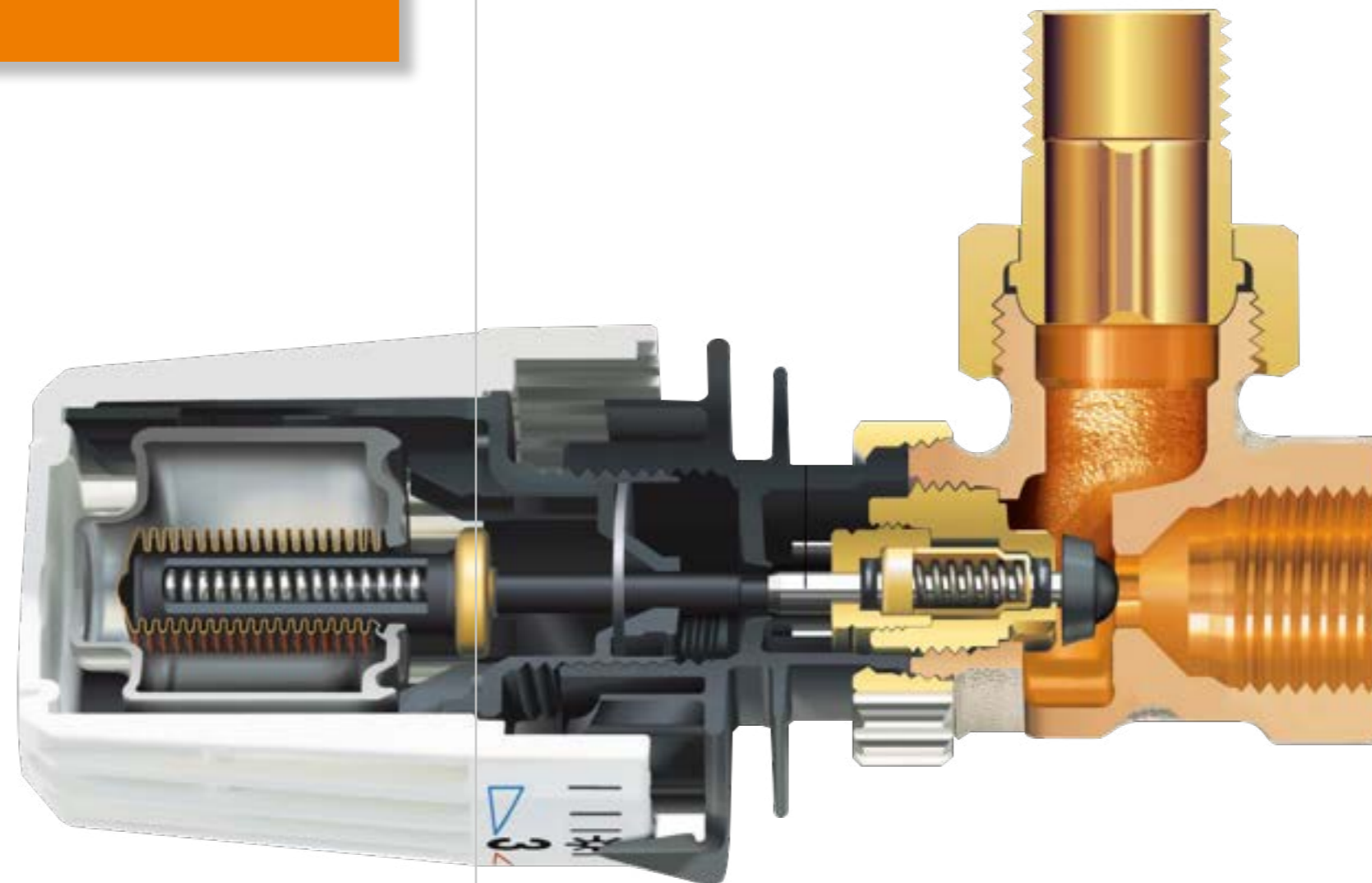

During the summer months when the heating system is usually off, the thermostatic head may remain set at a specific temperature (e.g., 20°C). This can lead to the valve remaining closed throughout the summer, causing the valve spindle and cone to become stagnant. Dirt, lime, magnetite, and rust can accumulate on the surfaces of the valve spindle and cone during this period. As a result, the mechanical spring may no longer be able to open the valve, leaving the affected rooms cold.

To prevent radiator valves from sticking, it is recommended to periodically operate the radiator thermostat head during the summer and keep it fully open if possible (position #5). Regularly actuating the valve spindle and cone makes it difficult for dirt and deposits to adhere strongly, minimising the chances of valve sticking.

### Maintenance-free Heimeier radiator valves do not stick!

Installing high-quality radiator valves and heads effectively prevents issues. These valves are renowned for their exceptional reliability, never getting stuck like other well-known brands. Superior expansion materials and a robust mechanical spring enable the valve spindle and closing cone to operate smoothly, even in the presence of dirt or deposits. That's why IMI Heimeier radiator valves are proudly labeled as "maintenance-free," showcasing just one among the numerous quality features of the IMI Heimeier brand.

## Step-by-step guide to unstick the valve

- 1 Remove the thermostatic head to access the valve spindle and insert.  
  
Use a screwdriver to gently push the valve spindle into the radiator valve, trying different amounts of force and intervals. If unsuccessful, tap the side of the radiator valve with the metal part of the screwdriver (screwdriver metal part in hand, handle on radiator valve). Repeat these two techniques alternately until the mechanical spring releases the valve spindle from the blocked position and the radiator starts to warm up again.
- 2 In case of heavy dirt and deposits, a rubber hammer can also be used instead of a screwdriver. The knocking and pressing is intended to loosen the deposits and dirt on the valve spindle. However, please never hit the valve spindle directly with the hammer, only at the valve housing.
- 3 Install the radiator thermostat and set the desired room temperature (position #3 for 20°C).

If none of these solutions works and the valve cannot be loosened, it may be necessary to replace either the valve or the valve bonnet, which could involve emptying, refilling, and venting the heating system, potentially requiring up to 2 days of work. Alternatively, newer radiator thermostatic valves offer the option of replacing existing valve tops under pressure using a specialised tool called a "Fitting tool" (Article number 9721-00.000).



### Fitting tool

Fitting tool for replacing thermostatic inserts without draining off the heating system. Suitable for HEIMEIER thermostatic valve bodies from end of 1982, with connection thread for the thermostatic head on valve body, DN 10 to DN 20. Complete with case, box spanner and replacement seals. From 2013, equipped with black handwheel, also suitable for A-exact.



## Customer Q&A

### Question #2

How can customers save energy without replacing old radiators?

To enhance energy savings in existing systems, along with effective air and dirt removal and hydraulic balancing, replacing old thermostatic radiator heads is the simplest, yet most powerful, solution.

**By upgrading to new thermostatic heads, energy consumption can be reduced by 28% compared to manual ones.**

IMI Heimeier Thermostatic Head K comes with energy-saving clips for added convenience and efficiency:

- The **blue energy-saving clip** limits the lower temperature setting, such as the night setting.
- The **red energy-saving clip** restricts the upper temperature range and prevents accidental high temperature adjustments.

These clips also prove highly practical during room ventilation. By retracting the blue clip, the thermostatic head can be temporarily set to 0 without losing the preferred temperature range.

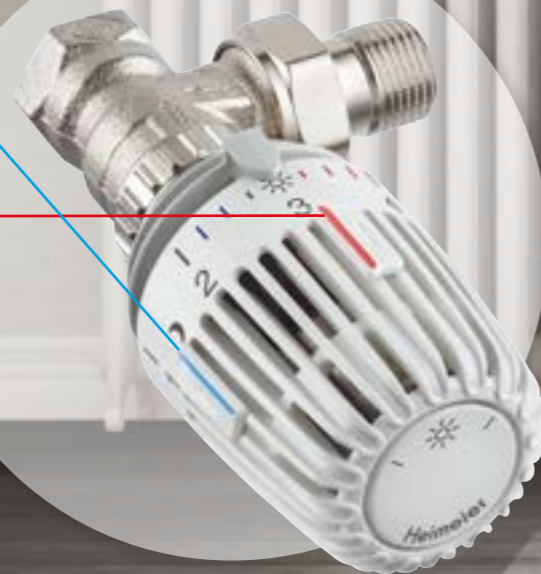

# Our products in action

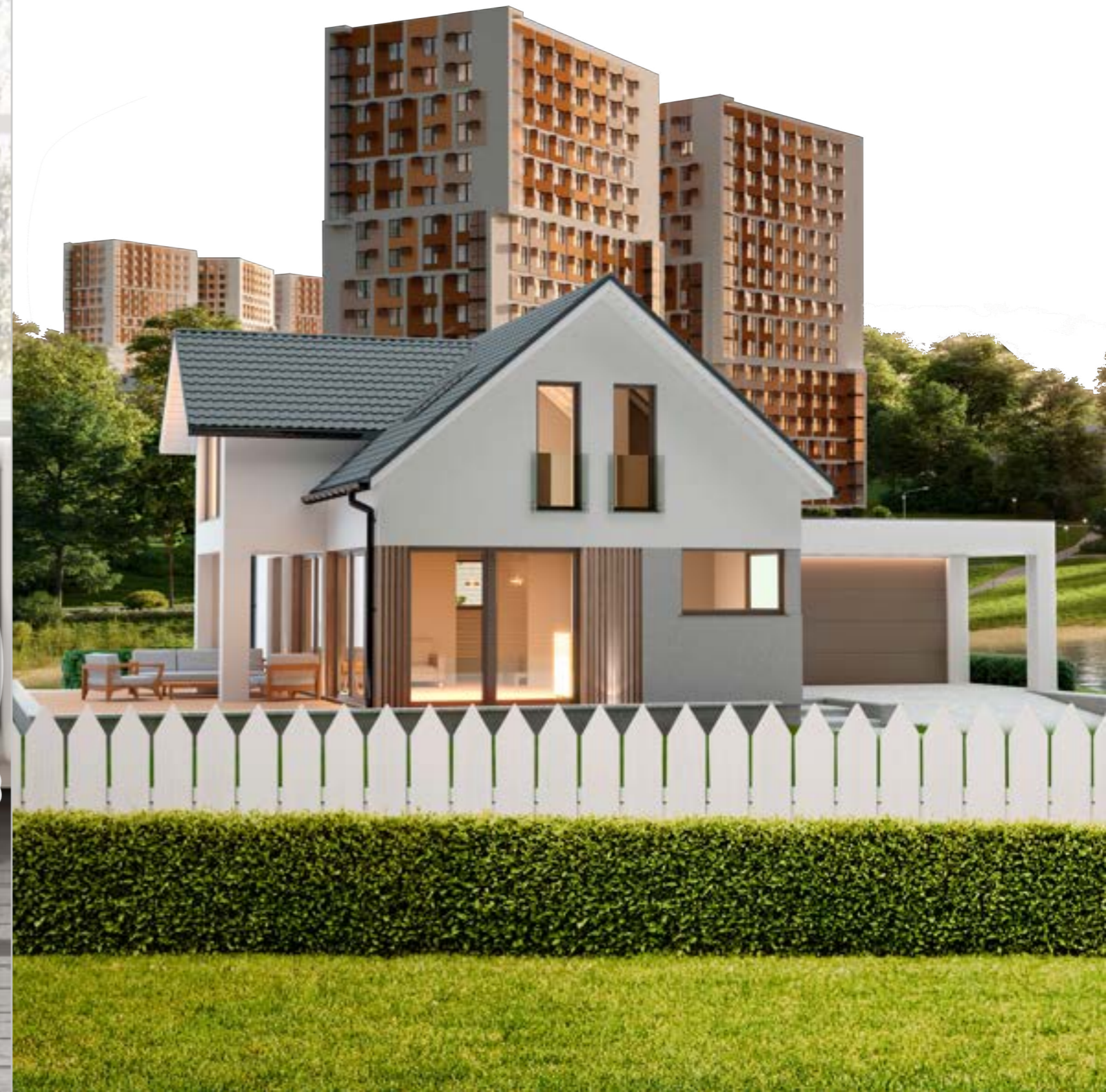





# Small residential applications

## Living areas

Flush-mounted individual room control

Multibox Eclipse

**WFC**

LEARN MORE

Thermostatic radiator valves

Eclipse

LEARN MORE

Thermostatic heads

Thermostatic head K

LEARN MORE

Wall thermostats

NeoAir / NeoStat

LEARN MORE

Automatic air vent, version Top

Zeparo ZUT

LEARN MORE

Radiator lockshield

Regulux

LEARN MORE

Floor heating manifold

Dynacon Eclipse

EMO T

LEARN MORE

Versatile shut-off valves

Globo H

LEARN MORE



# Small residential applications

## Boiler room

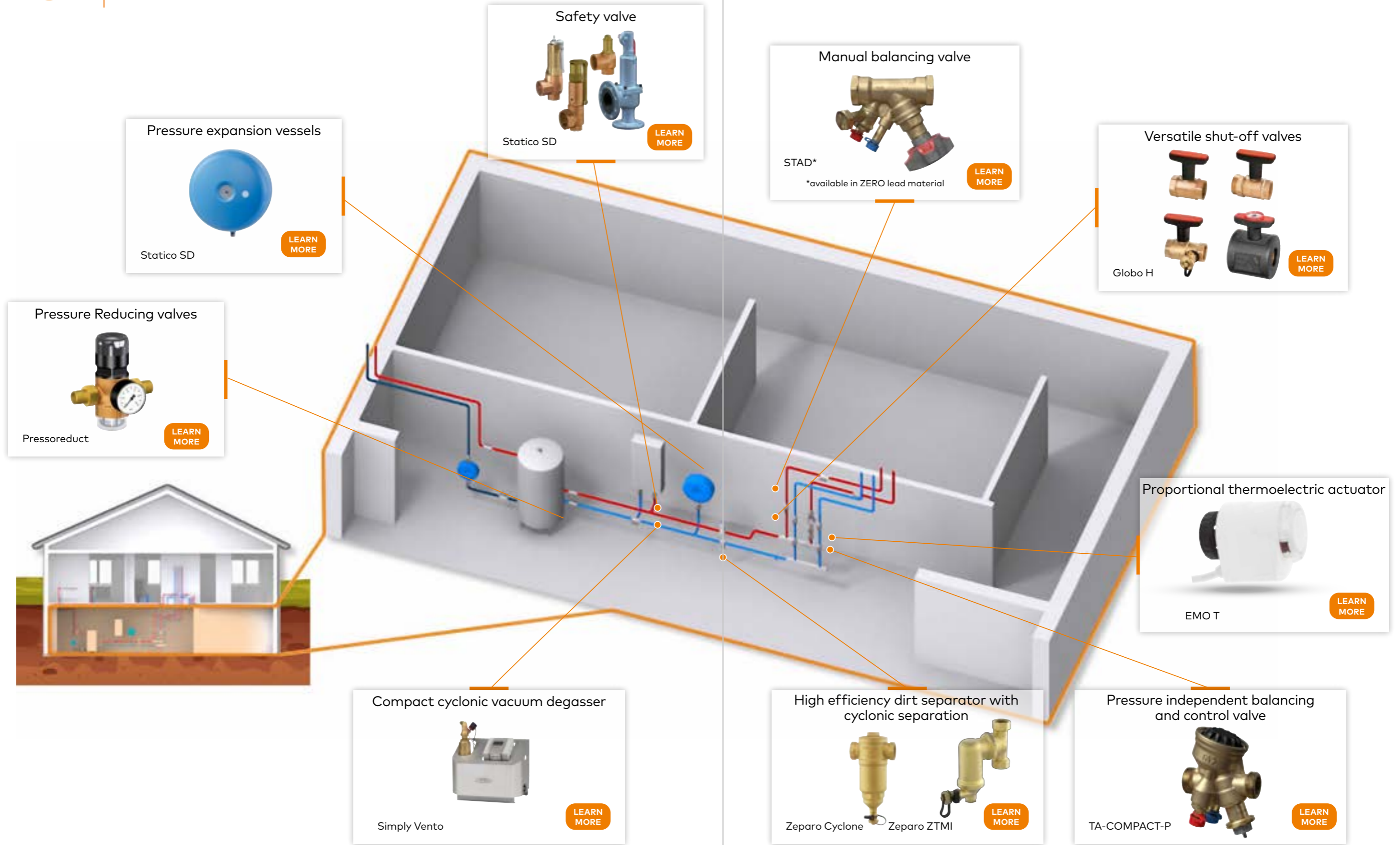

Pressure expansion vessels

Statico SD

[LEARN MORE](#)

Safety valve

Statico SD

[LEARN MORE](#)

Manual balancing valve

STAD\*

\*available in ZERO lead material

[LEARN MORE](#)

Versatile shut-off valves

Globo H

[LEARN MORE](#)

Pressure Reducing valves

Pressoreduct

[LEARN MORE](#)

Proportional thermoelectric actuator

EMOT

[LEARN MORE](#)

Compact cyclonic vacuum degasser

Simply Vento

[LEARN MORE](#)

High efficiency dirt separator with cyclonic separation

Zeparo Cyclone Zeparo ZTMI

[LEARN MORE](#)

Pressure independent balancing and control valve

TA-COMPACT-P

[LEARN MORE](#)



# Apartment building applications

## Living areas

Thermostatic heads

Thermostatic head K

LEARN MORE

Thermostat room temperature

NeoAir / NeoStat

LEARN MORE

Two-point connection for radiators with integrated valves

Multilux V Eclipse

LEARN MORE

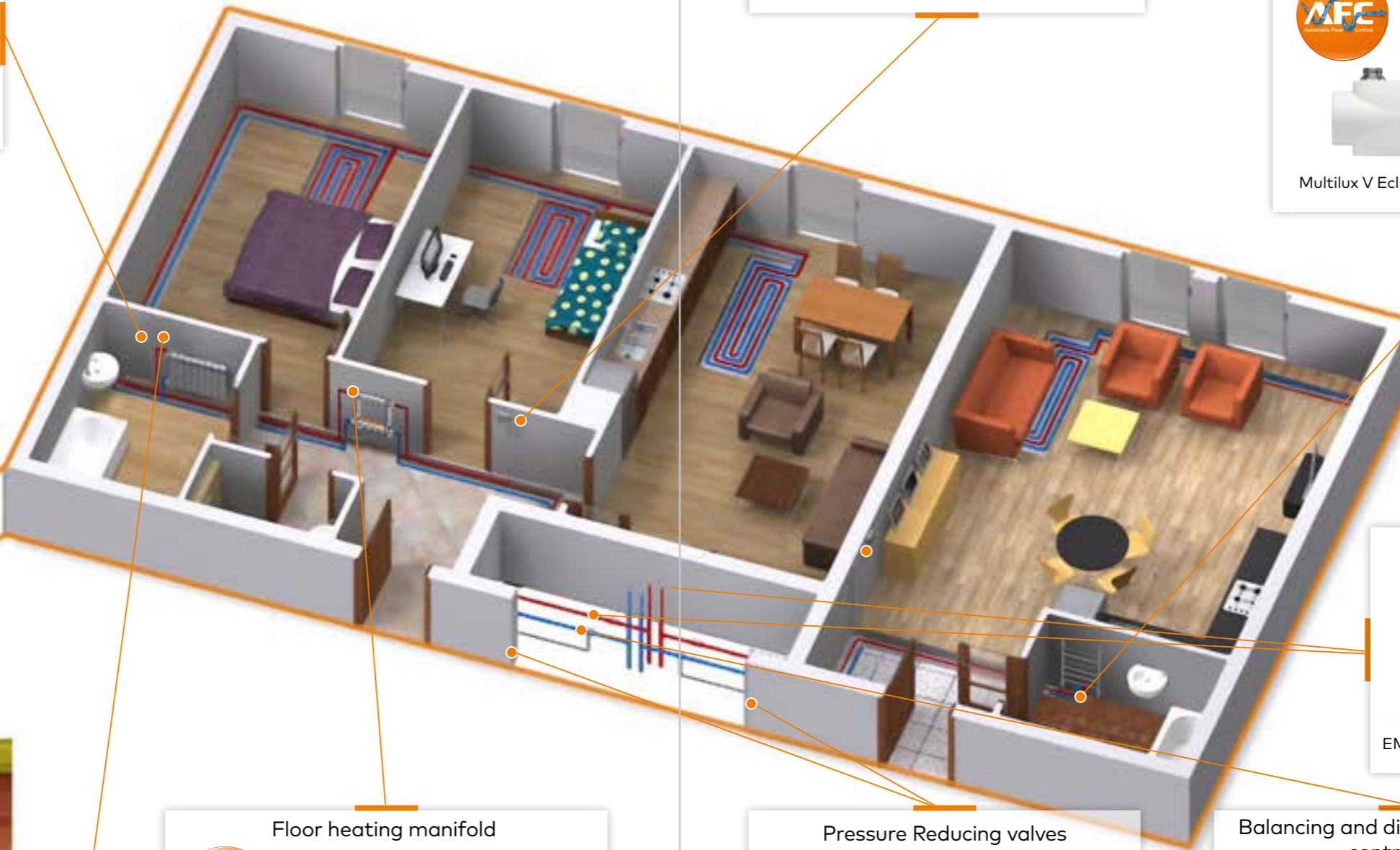
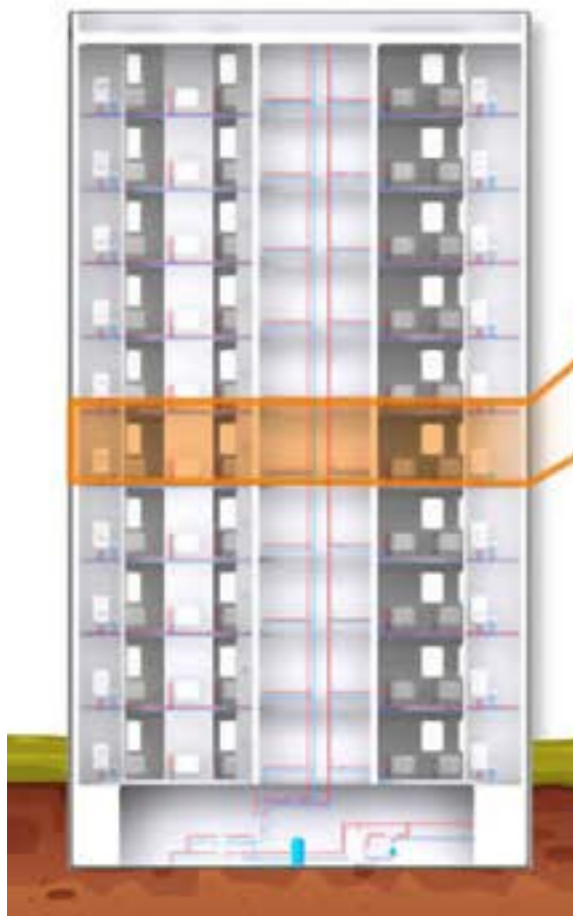

Thermostatic radiator valves

Eclipse

LEARN MORE

Floor heating manifold

Dynacon Eclipse

EMOT

LEARN MORE

Pressure Reducing valves

Pressoreduct

LEARN MORE

Thermoelectric actuator

EMO T

LEARN MORE

Balancing and differential pressure control valve

TA-COMPACT-DP

LEARN MORE



# Apartment building applications

## Boiler room

Pressure independent balancing and control valve with digitally configurable actuator

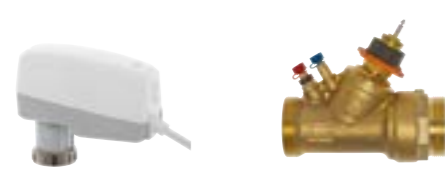

TA-Slider      TA-Modulator

[LEARN MORE](#)

Manual balancing and differential pressure control valve



STAD\*      STAP

\*available in ZERO lead material

[LEARN MORE](#)

Safety valve



Statico SD

[LEARN MORE](#)

Versatile shut-off valves



Globo H

[LEARN MORE](#)

2- or 3-way control valve



CV216/316 RGA

[LEARN MORE](#)

Thermostatic circulation valve



TA-Therm ZERO

[LEARN MORE](#)

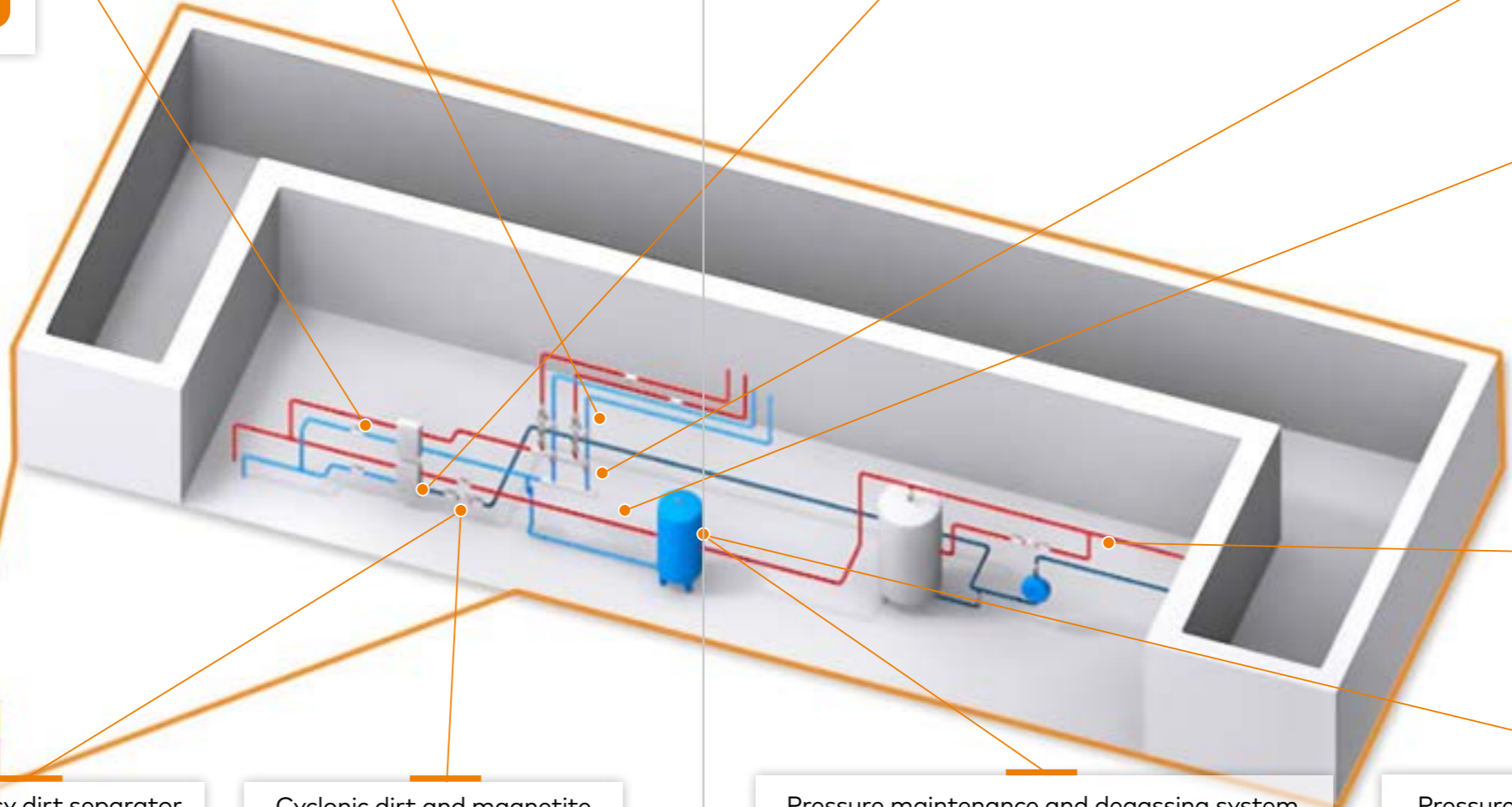
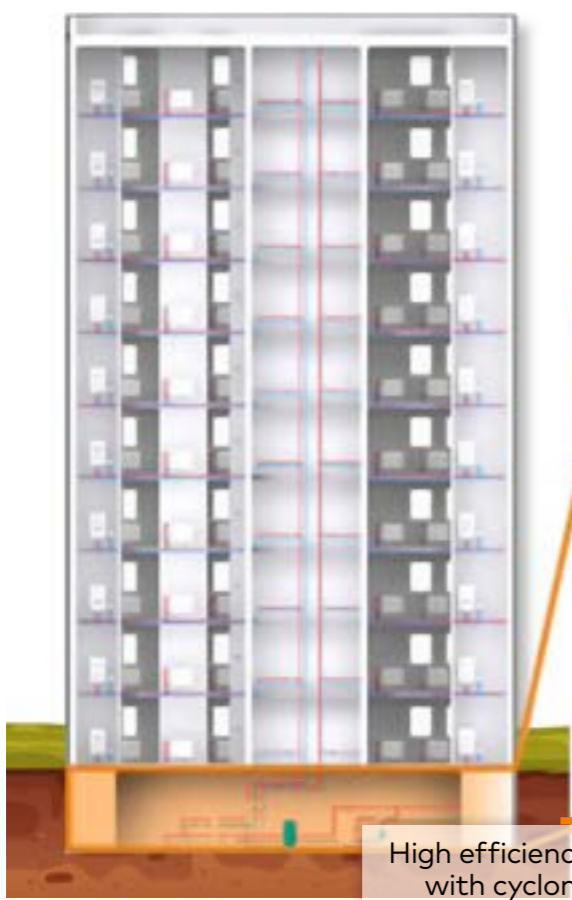

High efficiency dirt separator with cyclonic separation technology



Zeparo Cyclone

[LEARN MORE](#)

Cyclonic dirt and magnetite separator



Zeparo G-Force

[LEARN MORE](#)

Pressure maintenance and degassing system



Compresso Connect F      Vento Connect

[LEARN MORE](#)

Pressure maintenance and degassing system



Simply Compresso      Simply Vento

[LEARN MORE](#)

## Our expertise applied

Residential renovation projects have included:



### The Jever project in Northern Germany involved modernising a building housing 1,300 apartments.

IMI Hydronic's bespoke solution focused on combating heat loss by ensuring that the heating system was accurately balanced and no apartment was overheated or undercooled. Incorporating the business' IMI TA products, including balancing valves, differential pressure controllers, and thermostatic radiator valves, the new system delivered **energy savings of around 20% per annum.**

[Read more](#)



### The refurbishment of two large residential complexes in the Netherlands owned by the Wageningen Housing Association.

IMI Hydronic developed an energy-saving solution that involved the installation of IMI Heimeier Eclipse thermostatic valves in combination with thermostatic K-Heads, in **490 apartments.** With built-in sensors and automatic frequency control technology, the easy-to-install and commission Eclipse thermostatic valves automatically regulate the flow of water through the heating system and enable precise control of individual room temperatures without the need for constant adjustment.

[Read more](#)



### The renovation of a large 1970s housing complex in Sundsvall, Sweden containing more than 230 apartments spread across 30 buildings.

The project's key objective was to increase comfort within each apartment and, at the same time, reduce heating costs. Together with the complex owner, IMI Hydronic designed a new energy-efficient system incorporating balancing valves, including the STAD valve, which accurately regulates water flow, and thermostatic radiator valves that deliver optimal room temperature control. **Annual energy consumption across the complex was reduced by 15%** and comfort levels within each apartment were significantly improved.

[Read more](#)

 IMI PNEUMATEX

 IMI TA

 IMI HEIMEIER

**IMI Hydronic Engineering**  
Route de Crassier 19  
CH-1262 Eysins  
Switzerland

[www.imi-hydronic.com](http://www.imi-hydronic.com)

**IMI** Hydronic  
Engineering

ENG-10/2023