

Climate  
Control

IMI TA

# STAD ZERO



## Balancing valves

DN 10-50 made of lead-free brass  
(less than 0,1% lead)

# STAD ZERO

The STAD ZERO balancing valve delivers accurate hydronic performance in an impressive range of applications. Ideally suited for use on the secondary side in heating and cooling systems, and tap water systems. The STAD ZERO is a lead-free product (<0.1% lead content) especially designed to address local environmental demands.



## Key features

### ZERO lead

Product made of lead-free brass (<0.1% lead content).

### High accuracy for all settings

Ensure accurate balancing and flow reading.

### Handwheel

Equipped with a digital read-out, the handwheel ensures accurate and straightforward balancing. Positive shut-off function for easy maintenance.

### Self-sealing measuring points

For simple, accurate balancing.

## Technical description

### Application:

Heating and cooling systems  
Tap water systems

### Functions:

Balancing  
Pre-setting  
Measuring  
Shut-off  
Draining

### Dimensions:

DN 10-50

### Pressure class:

PN 25

### Temperature:

Max. working temperature: 120°C  
(intermittent 150°C)  
Min. working temperature: -20°C

### Media:

Water or neutral fluids, water-glycol mixtures (0-57%).

### Material:

Valve body and bonnet: Brass CC768S  
Sealing (body/bonnet): EPDM O-ring  
Valve plug: Brass CW724R (CuZn21Si3P)  
Seat seal: EPDM O-ring  
Spindle: Brass CW724R (CuZn21Si3P)  
Slip washer: PTFE  
Spindle seal: EPDM O-ring  
Spring: Stainless steel  
Handwheel: Polyamide and TPE

Measuring points: Brass CW724R (CuZn21Si3P)  
Sealings: EPDM  
Caps: Polyamide and TPE

Draining: Brass CC768S  
Sealing: EPDM  
Gaskets: Fiber-based aramid

### Marking:

Body: IMI, TA, PN 25/400 WWP, DN and inch size. DN 50 also CE.  
Handwheel: TA, STAD\* ZERO and DN.  
White id-tag.

### Connection:

Internal thread according to ISO 228.  
Thread length according to ISO 7/1.

### Approvals:

52 858-3xx: WaterMark, IAPMO R&T  
OCEANA. License No. WM-022578.

## Measuring points

Measuring points are self-sealed. Remove the cap and insert the probe through the seal.

## Draining

Valves with draining for G1/2 hose connection.

## Sizing

When  $\Delta p$  and the design flow are known, use the formula to calculate the Kv value or use the diagram.

$$Kv = 0,01 \frac{q}{\sqrt{\Delta p}} \quad q \text{ l/h, } \Delta p \text{ kPa}$$

$$Kv = 36 \frac{q}{\sqrt{\Delta p}} \quad q \text{ l/s, } \Delta p \text{ kPa}$$

## Kv values

The Kv ranges are valid for stated accuracy. For lower or intermediate values, please use softwares (HySelect, HyTools) or balancing instrument (TA-SCOPE).

Turns	DN 10	DN 15	DN 20	DN 25	DN 32	DN 40	DN 50
0.5	-	0.136	0.533	0.599	1.19	1.89	2.62
1	0.091	0.226	0.781	1.03	2.09	3.40	4.10
1.5	0.134	0.347	1.22	2.13	3.36	4.74	6.76
2	0.264	0.618	1.95	3.64	5.22	6.25	11.4
2.5	0.461	0.931	2.71	5.26	7.77	9.16	15.8
3	0.799	1.46	3.71	6.65	9.82	12.8	21.5
3.5	1.22	2.07	4.51	7.79	11.9	16.2	27.0
4	1.36	2.56	5.39	8.59	14.2	19.3	32.3

**NOTE:** In apps and balancing instrument the STAD ZERO is named STAD\*.

## Measuring accuracy

The handwheel zero position is calibrated and must not be changed.

### Deviation of flow at different settings

The curve (Fig. 1) is valid for valves with normal pipe fittings (Fig. 2). Try also to avoid mounting taps and pumps, immediately before the valve.

The valve can be installed with the opposite flow direction. The specified flow details are also valid for this direction although tolerances can be greater (maximum 5% more).

**Fig. 1**

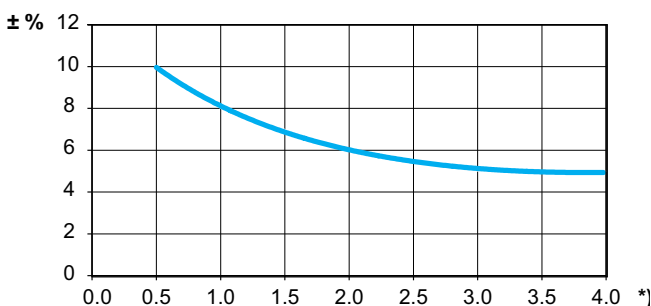

**Fig. 2**

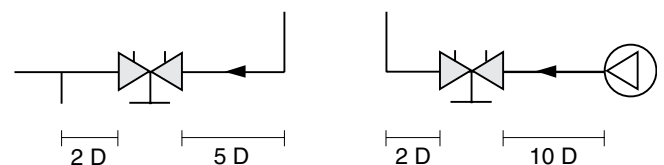

D = Valve DN

\*) Setting, No. of turns.

## Correction factors

The flow calculations are valid for water (+20°C). For other liquids with approximately the same viscosity as water ( $\leq 20 \text{ cSt} = 3^\circ \text{E} = 100 \text{ S.U.}$ ), it is only necessary to compensate for the specific density. However, at low temperatures, the viscosity increases and laminar flow may occur in the valves. This causes a flow deviation that increases with small valves, low settings and low differential pressures. Correction for this deviation can be made with the software HySelect or directly in our balancing instruments.

## Setting

Setting of a valve for a particular pressure drop, e.g. corresponding to 2.3 turns on the graph, is carried out as follows:

1. Close the valve fully (Fig. 1).
2. Open the valve 2.3 turns (Fig. 2).
3. Using a 3 mm Allen key, turn the inner spindle clockwise until stop.
4. The valve is now set.

To check the setting: Close the valve, the indicator shows 0.0. Open it to the stop position. The indicator then shows the set value, in this case 2.3 (Fig. 2).

Diagrams showing the pressure drop for each valve size at different settings and flow rates are available to help determine the correct valve size and pre-setting (pressure drop).

Four turns corresponds to fully open valve (Fig. 3). Opening it further will not increase the capacity.

**Fig. 1**  
Valve closed

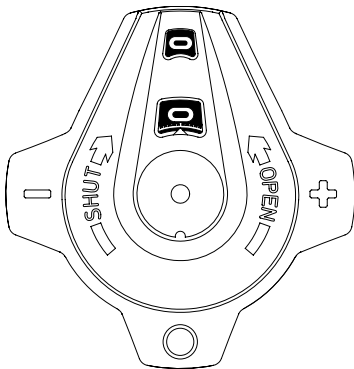

**Fig. 2**  
The valve is set at 2.3

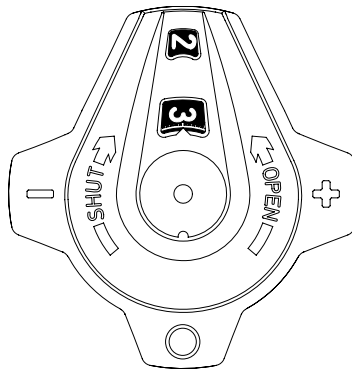

**Fig. 3**  
Fully open valve

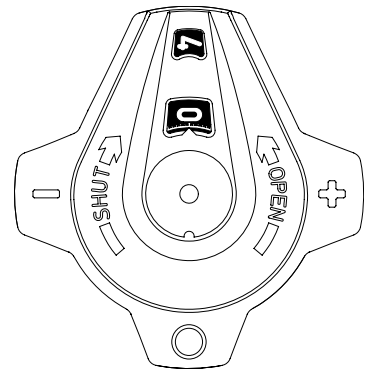

## Diagram example

### Wanted:

Presetting for DN 25 at a desired flow rate of 1,6 m<sup>3</sup>/h and a pressure drop of 10 kPa.

### Solution:

Draw a straight line joining 1,6 m<sup>3</sup>/h and 10 kPa. This gives Kv=5,06. Now draw a horizontal line from Kv=5,06. This intersects the bar for DN 25 which gives 2,44 turns.

### NOTE:

If the flow rate is out of the scale in the diagram, the reading can be made as follows:

Starting with the example above, we get 10 kPa, Kv=5.06 and flow-rate 1.6 m<sup>3</sup>/h.

At 10 kPa and Kv=0.506 we get the flow-rate 0.16 m<sup>3</sup>/h, and at Kv=50.6, we get 16 m<sup>3</sup>/h. That is, for a given pressure drop, it is possible to read 10 times or 0.1 times the flow and Kv-values.

### Diagram

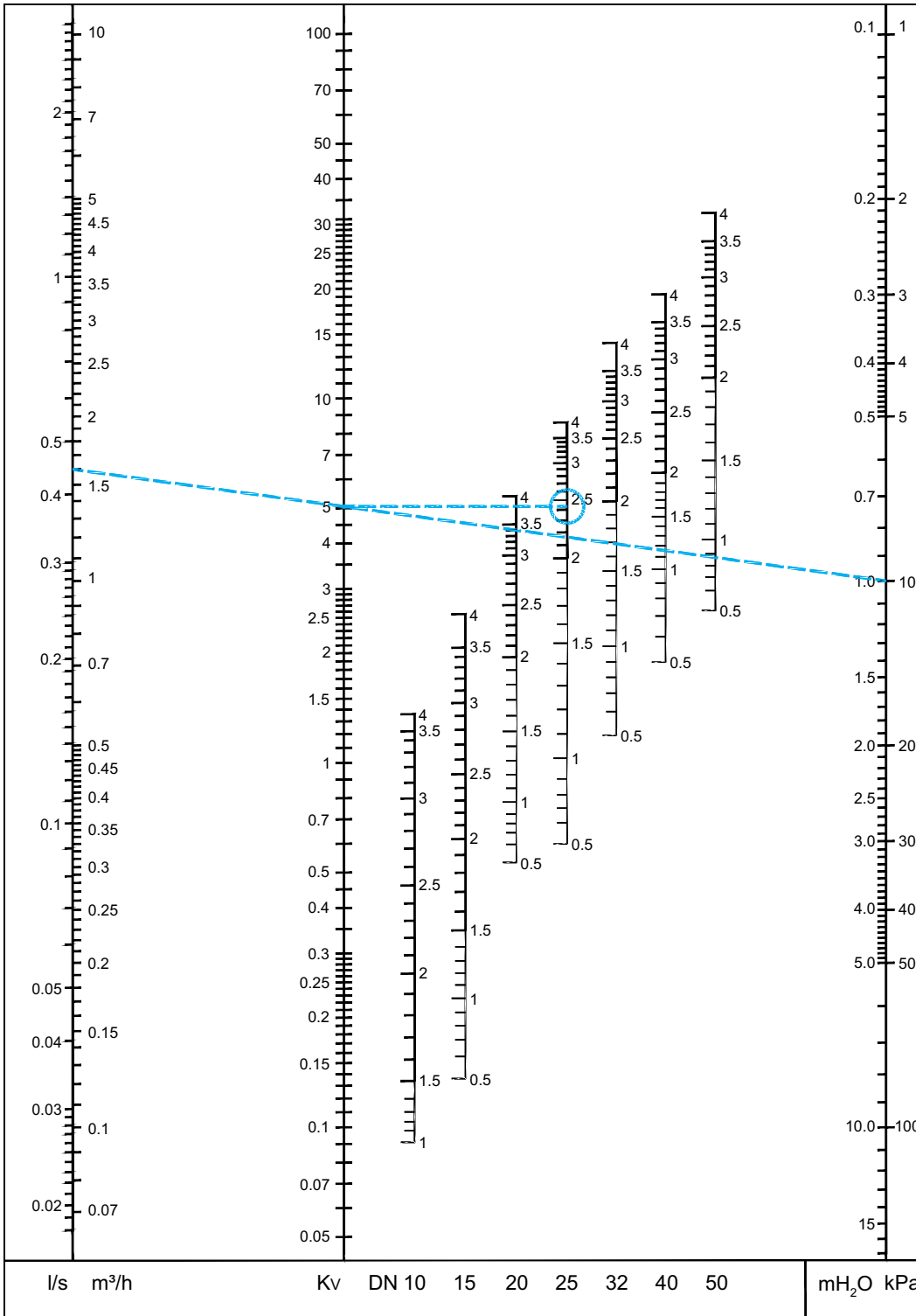

**NOTE:** In apps and balancing instrument the STAD ZERO is named STAD\*.

## Articles

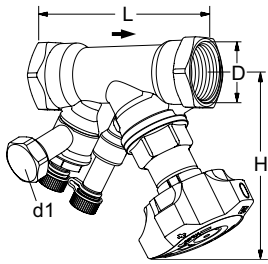

### With drain

Internal threads. Thread according to ISO 228. Thread length according to ISO 7/1.

DN	D	L	H	Kvs	Kg	EAN	Article No
<b>d = G1/2</b>							
10*	G3/8	73	100	1,36	0,53	5901688823729	52 853-210
15*	G1/2	84	100	2,56	0,56	5901688823750	52 853-215
20*	G3/4	94	100	5,39	0,64	5901688824146	52 853-220
25	G1	105	105	8,59	0,77	5901688824153	52 853-225
32	G1 1/4	121	110	14,2	1,1	5901688824160	52 853-232
40	G1 1/2	126	120	19,3	1,5	5901688824177	52 853-240
50	G2	155	120	32,3	2,1	5901688824184	52 853-250

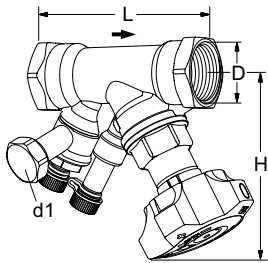

### With drain

Internal threads. Thread according to ISO 228. Thread length according to ISO 7/1.

### WaterMark (IAPMO R&T OCEANA)

DN	D	L	H	Kvs	Kg	EAN	Article No
<b>d = G1/2</b>							
10*	G3/8	73	100	1,36	0,53	5902276827624	52 858-310
15*	G1/2	84	100	2,56	0,56	5902276827631	52 858-315
20*	G3/4	94	100	5,39	0,64	5902276827648	52 858-320
25	G1	105	105	8,59	0,77	5902276827655	52 858-325
32	G1 1/4	121	110	14,2	1,1	5902276827662	52 858-332
40	G1 1/2	126	120	19,3	1,5	5902276827679	52 858-340
50	G2	155	120	32,3	2,1	5902276827686	52 858-350

→ = Flow direction

\*) Can be connected to smooth pipes by KOMBI compression coupling.

Kvs = m<sup>3</sup>/h at a pressure drop of 1 bar and fully open valve.

**NOTE:** In apps and balancing instrument the STAD ZERO is named STAD\*.

## Accessories

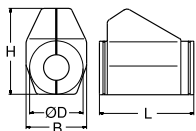

### Insulation

For heating/cooling

Material: EPP

Fire class: B2 (DIN 4102)

Max working temperature: 120°C  
(intermittent 140°C)

Min working temperature: 12°C,  
-8°C at sealed joints.

For DN	L	H	D	B	EAN	Article No
10-20	155	135	90	103	7318792839108	52 189-615
25	175	142	94	103	7318792839306	52 189-625
32	195	156	106	103	7318792839504	52 189-632
40	214	169	108	113	7318792839702	52 189-640
50	245	178	108	114	7318792839900	52 189-650