

Climate
Control

IMI TA

TA-Sixline – NPT threads



Standard control valves

6-way valve for change-over systems

TA-Sixline – NPT threads

TA-Sixline is a compact and efficient linear 6-way valve designed for 4-pipe systems where both heating and cooling are required through a single terminal unit. Its linear design provides precise control and stable regulation across all positions. It is designed to be used in combination with the TA-Slider 200, ensuring seamless integration and easy commissioning.

Key features

Easy commissioning and balancing

Simple Cv setup via TA-Slider, without need of PLC or selection of specific Cv inserts.

Wide flow range

Wide Cv range per variant. Reduces complexity and installation errors on the field.

Flexibility

Ports A and B have the same characteristic and Cv, which allows flexibility and eliminate mixing of heating and cooling errors during installation.

Ease of installation

Compact design with 360° actuator orientation. M8 connector for ceiling fixation.



Technical description - TA-Sixline

Application:

Heating (not steam) and cooling systems. (Change-over system)

Functions:

Control
Pre-setting (max Cv heating and cooling)
Pressure compensation

Dimensions:

1/2"

Cv range:

The Cv can be set within the range:

1/2": 0.088 - 0.88

1/2" HF: 0.128 - 1.287

HF = High flow

Pressure class:

PN 16 (230 psi)

Max. differential pressure (Δp_V):

22 psi over control part

Max. close off pressure:

58 psi

Temperature:

Max. working temperature: 194 °F

Min. working temperature: 32 °F

Media:

Water or neutral fluids, water-glycol mixtures (0-57%).

Leakage rate:

Tight sealing (Class VI according to EN 60534-4).

Characteristics:

Linear

Material:

Valve body and pistons: AMETAL®

Middle spindle: Brass CW724R (CuZn21Si3P)

Top spindle: Stainless Steel 1.4305 (X8CrNiS18-9)

Internal plastic parts: PPS

O-rings: EPDM

AMETAL® is the dezincification resistant alloy of IMI.

Connection:

External thread according to ISO 228.

Connections (accessories) with internal and external thread NPT according to ANSI/ASME B1.20.1-1983, or for soldering according to ASME/ANSI B16.18.

Internal thread according to ISO 228.

Marking:

IMI TA, PN, DN, A/B flow direction

Connection to actuator:

M30x1.5, push/pull

Stroke:

Total stroke: 0.433 in.

A-side: 0.167 in.

No flow zone: 0.098 in.

B-side: 0.167 in.

Actuator:

TA-Slider 200

Technical description - TA-Slider 200 I/O

Functions:

Proportional control
 Manual override (TA-Dongle)
 Stroke detection
 Mode, status and position indication
 Stroke limitation setting
 Minimum stroke setting
 Valve blockage protection
 Valve clogging detection
 Error safe position
 Diagnostic/Logging
 Delayed start-up

1 binary input, max. 100 Ω , cable max.
 32.8 ft or shielded.
 Output signal

Supply voltage:

24 VAC/VDC $\pm 15\%$.
 Frequency 50/60 Hz ± 3 Hz.

Power consumption:

Operation: < 1.3 VA (VAC); < 0.7 W (VDC)
 Standby: < 0.5 VA (VAC); < 0.25 W (VDC)

Input signal:

0(2)-10 VDC, R_i 47 k Ω .
 Adjustable hysteresis sensitivity 0.1-0.5 VDC.
 0.33 Hz low pass filter.
 Proportional:
 0-10, 10-0, 2-10 or 10-2 VDC.
 Proportional split-range:
 0-5, 5-0, 5-10 or 10-5 VDC.
 0-4.5, 4.5-0, 5.5-10 or 10-5.5 VDC.
 2-6, 6-2, 6-10 or 10-6 VDC.
 Proportional dual-range (for change-over):
 0-3.3 / 6.7-10 VDC,
 2-4.7 / 7.3-10 VDC,
 0-4.5 / 5.5-10 VDC or
 2-5.5 / 6.5-10 VDC.
 Default setting: Proportional 0-10 VDC.

Output signal:

0(2)-10 VDC, max. 8 mA, min. 1.25 k Ω .
 Ranges: See "Input signal".
 Default setting: Proportional 0-10 VDC.

Characteristics:

Linear, EQM 0.25 and inverted EQM 0.25.
 Default setting: Linear.

Control speed:

254 s/in (10 s/mm)

Adjusting force:

Push/Pull 45 lbf. (200 N)

Temperature:

Media temperature: max. 248 $^{\circ}$ F
 Operating environment: 32 $^{\circ}$ F to 122 $^{\circ}$ F
 (5-95 %RH, non-condensing)
 Storage environment: -4 $^{\circ}$ F to 158 $^{\circ}$ F
 (5-95 %RH, non-condensing)

Ingress protection:

IP54 all directions
 (according to EN 60529)

Protection class:

(according to EN 61140)
 III (SELV)

Cable:

3.28 ft, 9.84 ft or 16.4 ft. With wire end
 sleeves.
 Halogen free as option, fire class
 B2_{ca} – s1a, d1, a1 according to EN 50575.
 Type LiYY, 5x23 AWG (5x0.25 mm²).

Stroke:

0.64 in (16.2 mm)
 Automatic detection of the valve lift
 (stroke detection).

Noise level:

Max. 30 dBA

Weight:

0.44 lb, 3.28 ft cable
 0.55 lb, 9.84 ft cable
 0.84 lb, 16.4 ft cable

Connection to valve:

Retainer nut M30x1,5.

Material:

Cover: PC/ABS GF8
 Housing: PA GF40.
 Retainer nut: Nickel-plated brass.

Color:

White RAL 9016, grey RAL 7047.

Marking:

Label: IMI TA, CE, product name, article
 No. and technical specification.

Certification CE:

LV-D. 2014/35/EU: EN 60730-1, -2-14.
 EMC-D. 2014/30/EU: EN 60730-1, -2-14.
 RoHS-D. 2011/65/EU: EN 63000.

Product standard:

EN 60730

Function

Change-over control

The change-over can be implemented by:

- binary input that switches directly between heating and cooling.
- 0–10 V dual-range signal configured in the HyTune app to define the control ranges for each mode.

In the body of the valve it is marked the direction of the flow and which port corresponds. Port assignment is configurable in HyTune. Ports A and B can each be set to heating or cooling. Both ports have the same nominal Cvs, ensuring consistent flow performance regardless of assignment. The flow direction (inlet/outlet) can also be reversed if needed; note that reversal introduces a slight deviation from the specified Cv. This flexibility makes the TA-Sixline suitable for a wide range of terminal units and control systems.

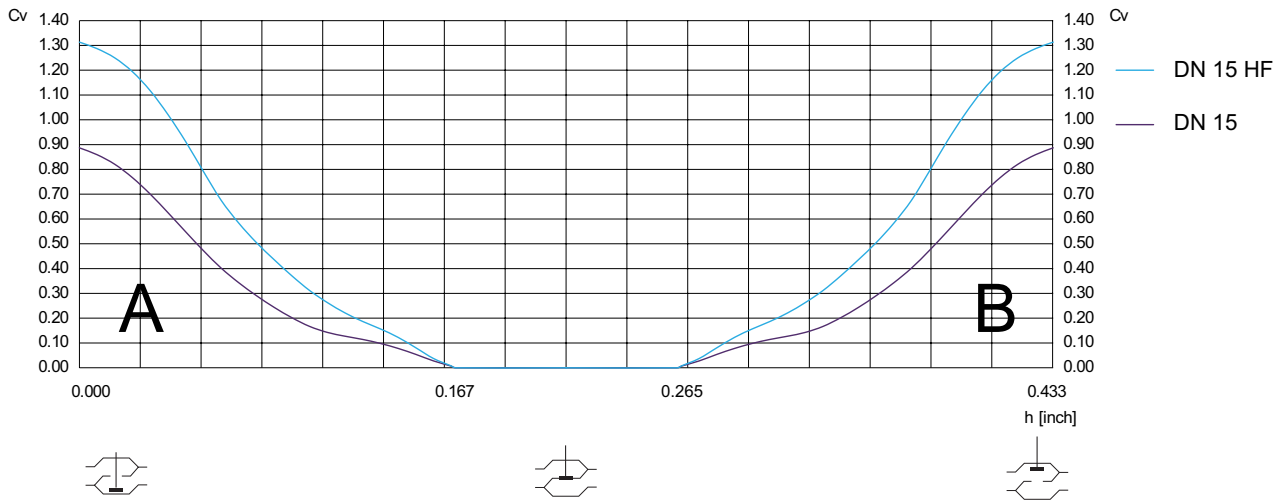

Hydronic balancing

The TA-Sixline, when used with the TA-Slider 200, allows the user to limit the Cv values for the heating and cooling ports independently. This is configured via the HyTune app, where maximum stroke positions for each port can be defined.

Expansion safety mechanism

In combined heating/cooling applications, the fluid inside the valve and terminal unit may remain enclosed when both circuits are closed (no heating or cooling demand). Ambient temperature changes can then cause the fluid temperature – and therefore pressure – to rise or fall inside the valve body. To manage this, the TA-Sixline includes an integrated pressure compensation function that relieves excess pressure build-up. This ensures mechanical safety, prevents stress on the valve components, and avoids unintended flow or noise caused by thermal expansion of the trapped fluid.

Setting

The actuator can be set by the HyTune app (iOS version 16 or later, Android version 9 or later) + the TA-Dongle device, with or without the actuator power supplied.

The setting configuration can be stored in the TA-Dongle for setting of one or several actuators. Connect the TA-Dongle to the actuator and press the configuration button.

HyTune can be downloaded from the App Store or Google Play.

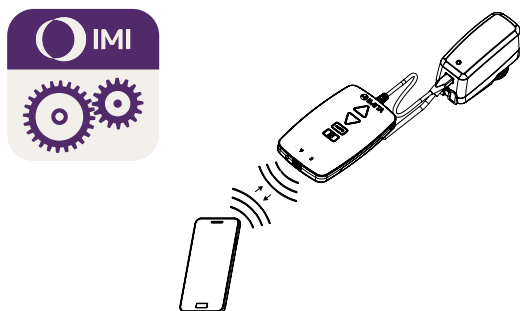

Manual override

By using the TA-Dongle device. No power supply needed.

Calibration/Stroke detection

According to selected settings in the table.

Type of calibration	At power on	After manual override
Both end positions (full)	√ *	√
Fully extended position (fast)	√	√ *
None	√	

*) Default

Note: A calibration refresh can be automatically repeated monthly or weekly.
Default setting: Off.

Stroke limitation setting

A maximum stroke smaller than or equal to the detected valve lift can be set to the actuator.

For some IMI TA/IMI Heimeier valves it can also be set to a Cv_{max}/q_{max} .

Default setting: No stroke limitation (100%).

Minimum stroke setting

The actuator can be set with a minimum stroke below which it will not go (except for calibration).

For some IMI TA/IMI Heimeier valves, it can also be set to a q_{min} .
Default setting: No minimum stroke (0%).

Valve blockage protection

If no actuation is performed for one week or one month, the actuator will perform one full stroke cycle.

Default setting: Off.

Valve clogging detection

If actuation stops before the desired value is reached, the actuator moves back ready to make a new attempt. The actuator will move to the configured error safe position after three attempts.

Default setting: On.

Error safe position

Fully extended or retracted position when following errors occur; low power, line break, valve clogging or stroke detection failure.

Default setting: Fully extended position.

Diagnostics/logging

The last 10 errors (low power, line break, valve clogging, stroke detection failure) with time-stamps are readable by the HyTune app + TA-Dongle device. Time-stamps of past errors will be cleared if the power is disconnected.

Delayed start-up

The actuator can be specified a delay (0 to 1275 sec.) before starting up after a power supply cut. This is useful when used with a control system that has itself a long start-up time.

Default setting: 0 seconds.

Binary input

If the binary input circuit is open, the actuator will go to a set stroke, switch to a second stroke limitation setting or drive to its full stroke regardless of any limitations for flushing purpose. See also Change-over system detection.

Default setting: Off

Change-over system detection

Switching between two different stroke limitation settings by toggling the binary input or using the dual-range input signal.

Noise

In order to avoid noise in the installation, the valve must be correctly installed and the water de-aerated.

LED indication

TA-Slider 200 I/O

		Status	Red (heating) / Blue (cooling)
	— — — —	Fully retracted (actuator stem)	Long pulse - Short pulse
	— — — —	Fully extended (actuator stem)	Short pulse - Long pulse
	— — — —	Intermediate position	Long pulses
	— — — —	Moving	Short pulses
	— — — —	Calibrating	2 short pulses
		Manual mode or no power supply	Off

		Error code	Violet
	- - -	Power supply too low	1 pulse
	- - -	Line broken (2-10 V)	2 pulses
	- - - -	Valve clogging or foreign object	3 pulses
	- - - -	Stroke detection failure	4 pulses

If an error is detected, violet pulses are displayed as the red or blue status lights flash alternately. More detailed information, please see the HyTune app + TA-Dongle.

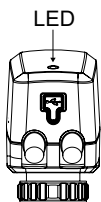

Installation

Installation of actuator

Note: Free space is required above the actuator for easy mounting/dismounting.

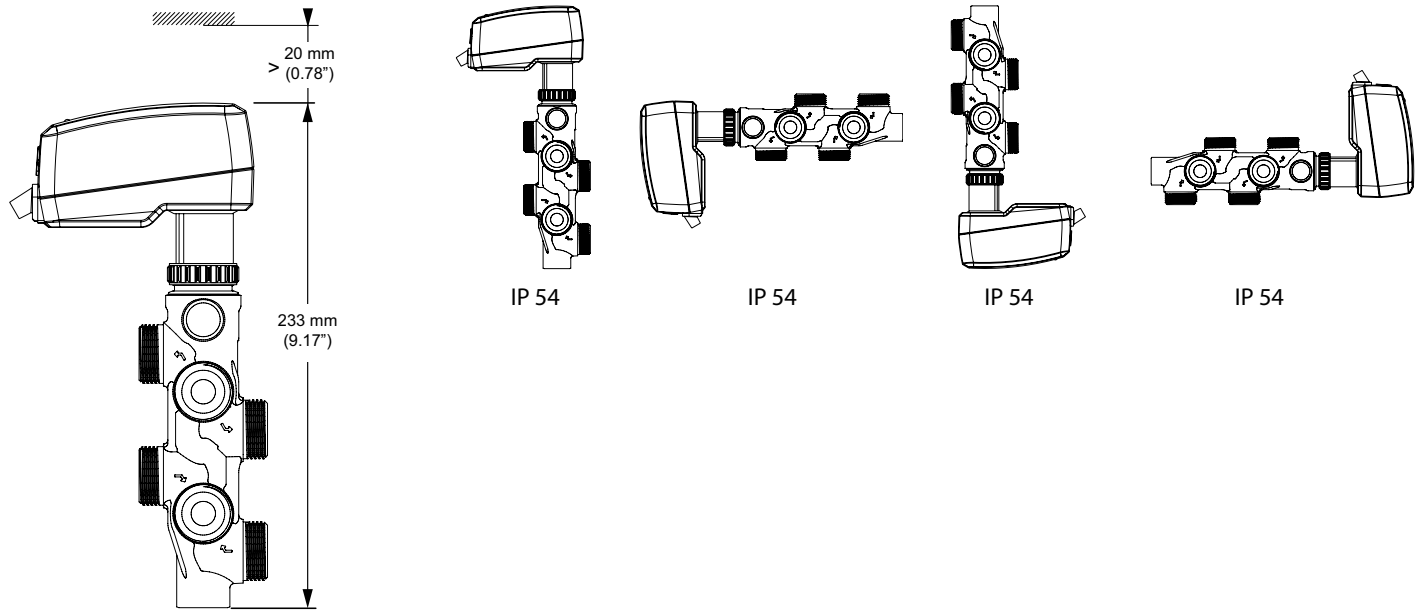

Pressurization

NOTE! When designing the pressurization system: please consider that change-over systems have hydraulic interaction between the cooling and the heating system via the terminals, which cause a fluid mass transfer from the cooling to the heating system. For further information please contact your local sales office.

M8 fixation

When flexible hoses are used to connect both the heating and cooling pipes as well as the radiant ceiling panels, a fixing mechanism is required.

The TA-Sixline can be mounted on a modular rail, which is secured to the ceiling, using an M8 screw.

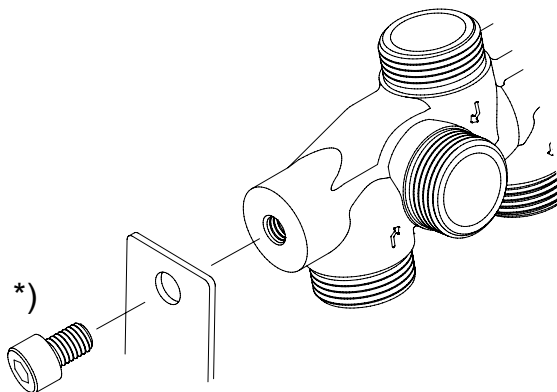

*) M8 screw is not included in the delivery

Application example

The TA-Sixline can be used to control a zone served either by multiple radiant ceiling panels or by a single panel.

When a zone includes several panels, a small manifold is installed on the emitter side of the TA-Sixline to distribute the flow to each panel.

For smaller zones with only one radiant ceiling panel, the panel can be connected directly to the emitter side of the TA-Sixline without a manifold.

The TA-Sixline is available with either internal or external threads on the emitter side to simplify system installation and minimize the number of required fittings, thereby reducing the risk of leakage during installation.

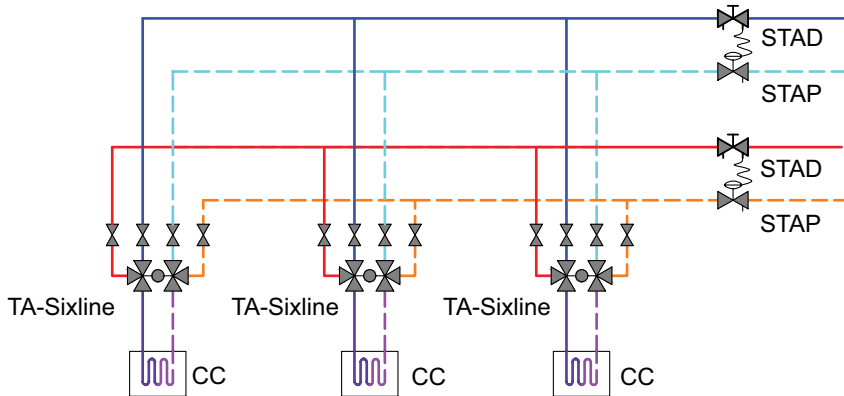

Example:

Heating flow needed 0.77 gpm, Cooling flow needed 1.89 gpm.

Available pressure over the TA-Sixline is estimated to 2.2 psi.

Heating

$$Cv = \frac{0.77}{\sqrt{2.2}} = 0.52$$

Cooling

$$Cv = \frac{1.89}{\sqrt{2.2}} = 1.29$$

Set Cv 0.52 and 1.29 in HyTune respectively.

Pump calculation:

Heating

Take index circuit.

Pressure drop from pump to differential pressure control valve (supply and return) = 4.4 psi

Pressure drop over differential pressure control valve = 0.92 psi (STAP 1" HySelect sizing of 8 x TA-Sixline of 0.77 gpm = 6.2 gpm).

Differential pressure setting is 2.9 psi, assuming 0.73 psi drop over branch pipes and climate ceilings (most of pressure drop) and 2.2 psi over TA-Sixline. Due to high pressure drop over valve and climate ceilings there is a little influence on "pressure drop in common pipes" hence flow limitation works at different loads (all or only few climate ceilings open/close).

Pressure drop in the branch equals to setting on differential pressure control valve = 2.9 psi.

Pump head pump 8.7 psi, it is recommended to set pump head as part of commissioning process by securing minimum pressure drop on differential pressure control valve when its setting secure total flow through branch is equal of sum of all climate ceilings.

Cooling

Take index circuit.

Pressure drop from pump to differential pressure control valve (supply and return) = 5.1 psi

Pressure drop over differential pressure control valve = 0.963 psi (STAP 1 1/2" HySelect sizing of 8 x TA-Sixline of 1.89 gpm = 14.7 gpm)

Differential pressure setting is 6.5 psi, assuming 4.3 psi drop over branch pipes and climate ceilings (most of pressure drop) and 2.2 psi over TA-Sixline. Due to high pressure drop over valve and climate ceilings there is a little influence on "pressure drop in common pipes" hence flow limitation works at different loads (all or only few climate ceilings open/close).

Pressure drop in the branch equals to setting on differential pressure control valve = 6.5 psi.

Pump head pump 13 psi, it is recommended to set pump head as part of commissioning process by securing minimum pressure drop on differential pressure control valve when its setting secure total flow through branch is equal of sum of all climate ceilings.

Connection diagram

TA-Slider 200 I/O

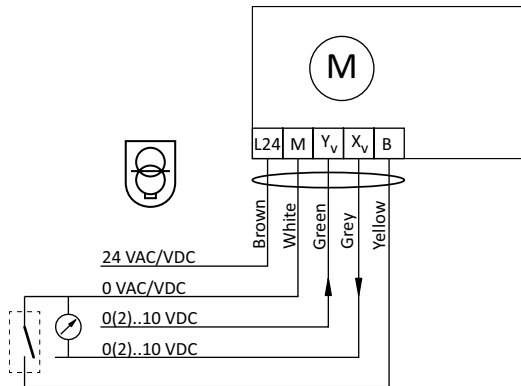

Terminal	Description
L24	Power supply 24 VAC/VDC
M	Neutral for power supply 24 VAC/VDC and signals.
Y _v	Input signal for proportional control 0(2)-10 VDC, 47 kΩ
X _v	Output signal 0(2)-10 VDC, max. 8 mA or min. load resistance 1.25 kΩ
B	Connection for potential free contact (e.g. open window detection), max. 100 Ω, max. 32.8 ft (10 m) cable or shielded



24 VAC/VDC operating only with safety transformer according to EN 61558-2-6.

Articles

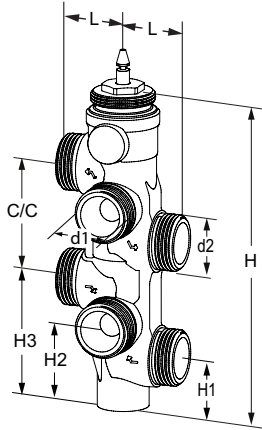

External threads

Threads according to ISO 228. NPT threads - see "Connections".

Size	(DN)	d1	d2	L	H	H1	H2	H3	C/C	Cvs	Weight	Article No
				[in]	[in]	[in]	[in]	[in]	[in]		[lb]	
External threads (6)												
1/2"	(15)	G3/4	G3/4	1.14	5.98	1.00	1.65	2.34	2.17	0.88	1.88	52 120-015
1/2" HF	(15 HF)	G3/4	G3/4	1.14	5.98	1.00	1.65	2.34	2.17	1.29	1.88	52 120-115

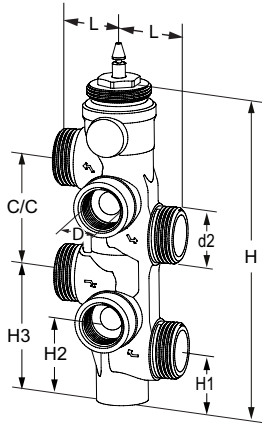

External thread x Internal thread

Threads according to ISO 228. NPT threads - see "Connections".

Size	(DN)	D	d2	L	H	H1	H2	H3	C/C	Cvs	Weight	Article No
				[in]	[in]	[in]	[in]	[in]	[in]		[lb]	
External thread (4) x Internal thread (2)												
1/2"	(15)	G1/2	G3/4	1.14	5.98	1.00	1.65	2.34	2.17	0.88	1.88	52 120-215
1/2" HF	(15 HF)	G1/2	G3/4	1.14	5.98	1.00	1.65	2.34	2.17	1.29	1.88	52 120-315

HF = High flow

Valve and actuator to be ordered and delivered separately.

TA-Sixline is designed to work only with TA-Slider 200. IMI cannot guarantee performance when used with other actuators.

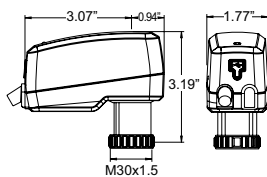

TA-Slider 200 I/O

Input signal: 0(2)-10 VDC

With binary input, VDC output signal

Cable length	Supply voltage	Article No
3.28 ft. (1 m)	24 VAC/VDC	322229-10411
9.84 ft. (3 m)	24 VAC/VDC	322229-10412
16.4 ft. (5 m)	24 VAC/VDC	322229-10413
With halogen free cable		
3.28 ft. (1 m)	24 VAC/VDC	322229-10414
9.84 ft. (3 m)	24 VAC/VDC	322229-10415
16.4 ft. (5 m)	24 VAC/VDC	322229-10416

Connections

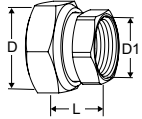

With internal thread NPT

Threads according to ANSI/ASME B1.20.1-1983.

Swivelling nut.
Brass/AMETAL®.

For size	D	D1	L [in] *	Article No
1/2"	G3/4	1/2 NPT	0.98	52 163-215

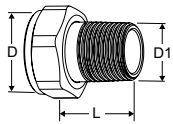

With external thread NPT

Threads according to ANSI/ASME B1.20.1-1983.

Swivelling nut.
Brass.

For size	D	D1	L [in] *	Article No
1/2"	G3/4	1/2 NPT	1.14	2400-02.350

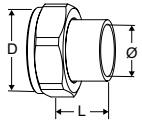

Soldering connection

According to ASME/ANSI B16.18.

Swivelling nut.
Brass/gunmetal CC491K (EN 1982).

For size	D	Pipe Ø [in]	L [in] *	Article No
1/2"	G3/4	0.629	0.63	52 009-715

*) Fitting length (from the gasket surface to the end of the connection).

Other type of connections (ISO), see international version of TA-Nano.

Accessories

Handwheel

For manual operation without actuator.

Article No

52 120-950

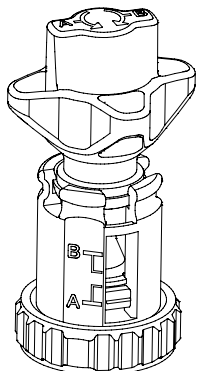

Additional equipment

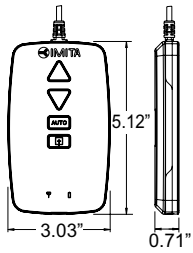

TA-Dongle

For Bluetooth communication with the HyTune app, transfer configuration settings and manual override.
(TA-Slider 200 I/O)

Article No
322228-00001